

# SKYSTREAM 3.7™

## OWNER'S MANUAL

Installation

Operation

Maintenance

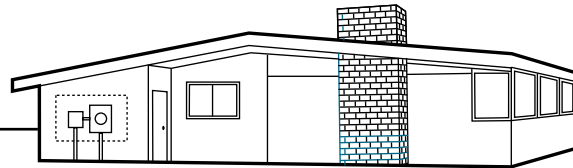

Southwest Windpower, Inc.  
1801 West Route 66  
Flagstaff, Arizona 86001  
Phone: 928.779.9463  
Fax: 928.779.1485

[www.skystreamenergy.com](http://www.skystreamenergy.com)

MADE IN THE **USA** © August 2007 Southwest Windpower, Inc.  
All Rights Reserved



## Southwest Windpower

**Congratulations on your purchase and welcome to our family!**

Dear Skystream 3.7™ Owner,

Thank you for your purchase of Skystream. You have just selected the most technologically advanced, cost-effective renewable energy appliance available for a home or small business. We congratulate you on your choice and are confident you will experience years of dependable service.

Before going any further, please complete and return the enclosed Warranty Registration Card. **The conditions of your warranty are dependent upon the proper installation of Skystream.** Furthermore, this will assure you of being kept up-to-date with the latest developments from Southwest Windpower. These include new options, performance tips, updated software to maximize output and user notices. It is important to know that we do not sell or distribute your information to any third party. We understand your privacy is important.

If you have any questions or comments, we would like to hear from you. Please call during working hours (Monday-Friday – 8:00am to 5:00pm Mountain Standard Time). Our number is **928-779-9463**, toll-free **866-807-9463**.

Again, welcome to our family and thank you for investing in the future of wind energy with Skystream.

Sincerely,

Southwest Windpower

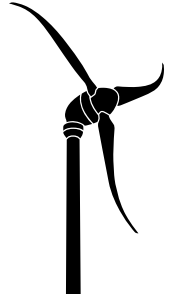

**Enter the serial and model number below**

Serial Number \_\_\_\_\_

Model Number \_\_\_\_\_

Skystream Installation Manual  
3-CMLT-1054  
Revision: H

## IMPORTANT SAFETY INSTRUCTIONS

READ THESE INSTRUCTIONS IN THEIR ENTIRETY BEFORE INSTALLING OR OPERATING.



**Professional installation** highly recommended

- 1) **SAVE THESE INSTRUCTIONS.** This manual contains important instructions for Skystream that must be followed during installation and maintenance.
- 2) Read, understand and respect all warnings.
- 3) Do not install Skystream around standing water.
- 4) Do not install Skystream on a windy day.
- 5) Install Skystream in accordance with National Electric Code (NEC) and local building codes.
- 6) Always obtain a building permit before construction.
- 7) When moving Skystream or any heavy objects to the site, use a cart to prevent back injury.
- 8) If unusual noise or abnormal operation is observed from Skystream, turn off the machine and contact authorized service personnel.
- 9) Shut Skystream "OFF" if ice accumulates on blades to avoid possible injury resulting from ice flying off blades.
- 10) This wind generator complies with international safety standards and therefore the design or its installation must never be compromised.
  - a. Do not open the inverter cover, doing so without factory authorization will void the warranty.
  - b. Apply the proper torque to all fasteners.
  - c. Torque field wire connections to Skystream to 20-25 inch-lbs. (2.3-2.5 N-m). Refer to Electrical Connections section of this manual (Section 2-1-2).
  - d. Install only on a Professional Engineer (PE) certified tower.
  - e. Do not paint the blades.
- 11) Use only proper grounding techniques as established by the NEC.
- 12) Properly complete the warranty registration card; failure to complete and return the card may affect your warranty.
- 13) Skystream must be installed in accordance with this manual and local and national building codes. Failure to comply with the manual and local codes will affect and possibly void your warranty.
- 14) Skystream uses high voltage and is potentially dangerous. Be sure to use all safety precautions at all times.

### In this manual



**IMPORTANT:**  
Please take note



**TIP:** Helpful information  
to ease the installation



**Professional installation**  
highly recommended



**Warning:** Risk of injury or  
death - proceed with extreme  
caution

## Contents

Important Safety Instructions _____	4
Skystream 3.7 Specifications _____	6-7
<b>1) BEFORE INSTALLATION _____</b>	<b>8</b>
<b>1-1 Package Contents _____</b>	<b>8</b>
<b>1-2 Recommended Tools _____</b>	<b>9</b>
<b>1-3 Skystream Options _____</b>	<b>10</b>
<b>1-4 Skystream Project Preparation _____</b>	<b>11</b>
<b>1-4-1 Finding the Best Location for Your Skystream _____</b>	<b>11</b>
<b>1-4-2 Tower Types _____</b>	<b>12</b>
<b>1-4-3 Working With Your Utility _____</b>	<b>12</b>
<b>1-4-4 Working With Your Local Zoning Authority _____</b>	<b>12</b>
<b>2) INSTALLATION _____</b>	<b>13</b>
<b>2-1 Electrical _____</b>	<b>13</b>
<b>2-1-1 Wiring _____</b>	<b>13</b>
<b>2-1-2 Electrical Connections _____</b>	<b>15</b>
<b>2-1-3 Wire Sizing _____</b>	<b>17</b>
<b>2-1-4 Grounding _____</b>	<b>17</b>
<b>2-1-5 Fusing/Circuit Breaker _____</b>	<b>17</b>
<b>2-1-6 Battery Charging _____</b>	<b>18</b>
<b>2-1-6-1 Battery Charging Option A _____</b>	<b>19</b>
<b>2-1-6-2 Battery Charging Option B _____</b>	<b>20</b>
<b>2-1-6-3 Battery Charging Option C _____</b>	<b>21</b>
<b>2-1-7 Batter Voltage Sensor Installation _____</b>	<b>22</b>
<b>2-2 Installing Skystream on a Tower _____</b>	<b>23</b>
<b>2-2-1 Mounting Skystream to the Tower _____</b>	<b>24</b>
<b>2-3 Testing on the Ground _____</b>	<b>24</b>
<b>2-3-1 Electrical Test _____</b>	<b>24</b>
<b>2-4 Blade, Nosecone and Antenna Assembly _____</b>	<b>26-27</b>
<b>3) OPERATION AND MAINTENANCE _____</b>	<b>28</b>
<b>3-1 Key Operating Characteristics _____</b>	<b>28</b>
<b>3-2 Electronic Stall Regulations _____</b>	<b>29</b>
<b>3-3 Redundant Relay Switch Control _____</b>	<b>29</b>
<b>3-4 Shutting Down the Skystream for Maintenance _____</b>	<b>30-31</b>
<b>3-5 Frequently Asked Questions _____</b>	<b>32</b>

## APPENDICES

### Appendix A: Electrical Diagrams

1 Grid Connection Option A _____	3
2 Grid Connection Option B _____	4
3 Grid Connection Option C _____	5
4 Grid Connection Option D _____	6
5 Grid Connection Option E _____	7
6 Battery Charging Option A _____	8
7 Battery Charging Option B _____	9
8 Battery Charging Option C _____	10
9 Battery Charging Option D _____	11
10 Battery Charging, Grid Connected Option A _____	12
11 Battery Charging, Grid Connected Option B _____	13
12 Battery Charging, Grid Connected Option C _____	14
13 Skystream Block Diagram _____	15

### Appendix B: Tower Grounding

1 Introduction _____	4
2 Grounding Techniques _____	4

### Appendix C: Compliance/Certification Documents

1 UL (US & Canada) _____	1
2 CE (Europe) _____	2

## Skystream 3.7™ Technical Specifications

<b>Model</b>	Skystream 3.7
<b>Rated Capacity</b>	1.8 kW rated 2.4 kW peak
<b>Weight</b>	170 lbs. / 77 kg
<b>Rotor Diameter</b>	12 feet / 3.72 meters
<b>Swept Area</b>	115.7 ft <sup>2</sup> / 10.87 m <sup>2</sup>
<b>Type</b>	Downwind rotor with stall regulation control
<b>Direction of Rotation</b>	Clockwise looking upwind
<b>Blades</b>	3 Fiberglass reinforced composite
<b>Rated Speed</b>	50 - 330 rpm
<b>Shutdown Speed</b>	370 rpm
<b>Tip Speed</b>	66 - 213 f/s / 9.7 - 63 m/s
<b>Alternator</b>	Slotless permanent magnet brushless
<b>Yaw Control</b>	Passive
<b>Grid Feeding</b>	Southwest Windpower Utility Interactive 120/240 VAC 50-60 Hz and 120/208 VAC, 60 Hz, 3 Ph.
<b>Braking System</b>	Electronic stall regulation w/redundant relay switch control
<b>Cut-in Wind Speed</b>	8 mph / 3.5 m/s
<b>Rated Wind Speed</b>	20 mph / 9 m/s
<b>User Control</b>	Wireless 2 way interface remote system
<b>Survival Wind Speed</b>	140 mph / 63 m/s
<b>Total Harmonic Distortion</b>	2.7% at 2400W, meets UL1741 and IEEE1547.1 requirements.
<b>Frequency Accuracy</b>	+/- 0.02 Hz
<b>Voltage Accuracy</b>	+/- 2.0 V (line to neutral)
<b>Surge Rating</b>	IEEE 1547 Surge Rating B

**PERFORMANCE GRAPH**

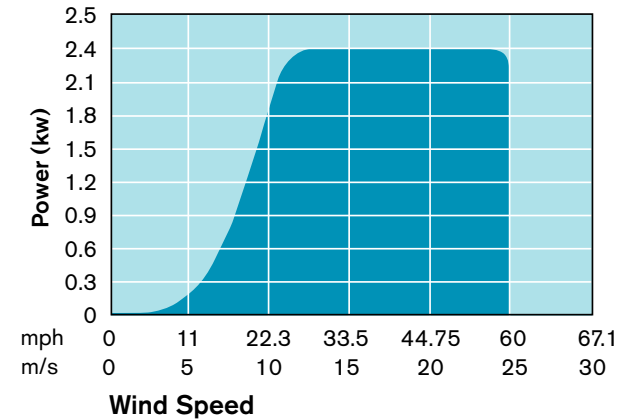

**ENERGY CHART**

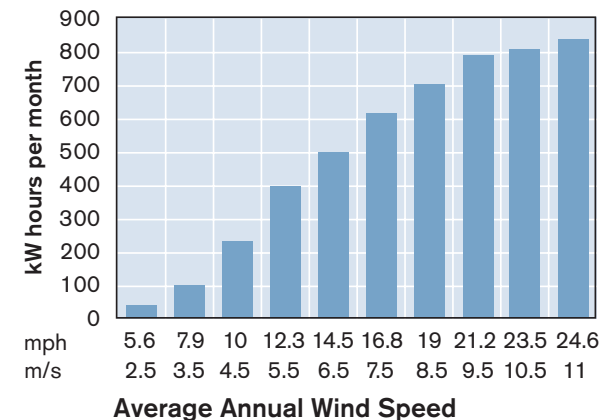

## Skystream 3.7™ Technical Specifications (continued)

### Voltage and Frequency Trip Points

Condition	Value	Units	Trip Time (sec)
Voltage stop minimum	105.6	volts	1.5
Voltage stop maximum	132	volts	0.75
Voltage fast stop minimum	60	volts	0.117
Voltage fast stop maximum	144	volts	0.117
Voltage start minimum	106.6	volts	—
Voltage start maximum	127	volts	—
Frequency stop minimum	59.3	Hz	0.1
Frequency stop maximum	60.5	Hz	0.1
Frequency start minimum	59.4	Hz	—
Frequency start maximum	60.4	Hz	—
Minimum Start Time after grid fault	300	seconds	—

### Tower Data (Loads calculated at 145 mph - 65 m/s)

**Note:** Loads do not include safety factor. Southwest Windpower recommends minimum safety factor of 1.5

Shaft Thrust 630	2802 lbs	N
Downward 210	932 lbs	N
Bending Moment 1130	1532 ft-lb	N.M.

## One - Before Installation

Instructions in this guide apply to the following Skystream Land and Marine models:

- 120/240VAC, 60Hz
- 120/208VAC, 60Hz
- 230VAC, 50Hz
- 120VAC, 60Hz

Please specify “land” or “marine” and voltage and frequency when ordering parts or requesting service as components differ.

### 1-1 Package Contents

Before you begin, inspect the contents to make sure there is no damage or missing parts.

- Identify the parts of your Skystream system using the information on the next two pages.
- Inspect for damage and/or missing parts.

Your Skystream wind generator is shipped in two boxes:

#### **Box One: rotor blades (three each)**

- Box dimensions: 76" L x 15" W x 12" H (193 cm x 38 cm x 31 cm)
- Weight: 40 lbs (18 kg)

Upon opening, carefully inspect each of the blades to make sure there are no fractures or cracks in the surfaces. Although the Skystream rotor blades are comprised of a durable compression molded fiberglass, damage can occur to the blades during shipping. Once inspected, be sure to set them away from the construction site and protect them from any damage until they are ready for assembly.

#### **Box Two: Skystream 3.7 wind generator assembly**

- Box dimensions: 40"L x 22"W x 27"H (102 cm L x 56 cm W x 69 cm H)
- Weight: 175 lbs (80 kg)

Your Skystream comes in several versions in accordance with local utility requirements. Be sure to inspect the package and confirm you have the right voltage and frequency. If you have ANY questions, call your dealer or the factory before continuing.



## Your Skystream shipment includes:

Your Skystream shipment includes the following components. A spare of each fastener (bolt, washer or nut) is included. The quantities indicated below are quantities required to assemble Skystream:

### RF Antenna

### Loctite® 242

### Turbine assembly with blade hub, retaining nut, blade plate and nosecone

### Blades and blade mounting hardware

- M10-1.5 x 120 socket head bolts, grade 10.9 (quantity 12)\*
- M10-1.5 nuts, grade 10.9 (quantity 12)
- M10 flat washers, A2 stainless steel (quantity 12)
- M10 lock washer, A2 stainless steel (quantity 12)
- Blade plate
- Blade hub
- M42, hub nut

### Nose cone with mounting hardware

- M6-1.0 x 12 socket head bolts, grade 8.8 (quantity 3)

\*Three blade bolts are shipped on blade hub, not in bolt kit bag.

### Yaw vibration isolators with mounting hardware

- Vibration Isolators (quantity 8)
- M12-1.75 x 90 hex head bolt, grade 10.9 (quantity 8)
- M12-1.75 nuts, grade 10.9 (quantity 8)
- M12 flat washers, A2 stainless steel (quantity 8)
- M12 lock washers, A2 stainless steel (quantity 8)
- M12 snubbing washers (quantity 8)

### Yaw shield (two halves) with mounting hardware

- M5-0.8x12 button head screws (quantity 4)

### Strain relief cover assembly with mounting hardware

- Strain relief cover with ground wire
- M5-0.8 x 12 socket head bolt (quantity 4)
- M5 lock washer A2 stainless steel (quantity 4)



**TIP:** See exploded view on pages 26-27

## 1-2 Recommended Tools





You will need the following tools to complete assembly of Skystream and install on the tower:

- 17 and 19 mm combination wrenches
- 19 mm socket for torque wrench
- Wire stripper, cutter
- Phillips head screwdriver
- Flat blade screwdriver socket for torque wrench
- Multi-meter
- Torque wrench, 0-100 lb-ft (135 N-m)
- Torque wrench, 0-50 lb-inch ( 5.6 N-m)
- 8 mm "allen" socket for torque wrench
- 3, 4, 5 & 8 mm allen wrenches

**Note:** This list does not include tools you will need for the construction of the tower or wire trench.

### 1-3 Skystream Options

There are a number of options that can enhance the experience of using a Skystream wind appliance. Although your Skystream will operate without them, we suggest reviewing this chapter. Contact Southwest Windpower or your dealer if you have questions.

	<p><b>Wireless Remote Display</b></p> <p>The optional remote display allows you to observe Skystream's performance in real time. You can also collect data such as KWh per day, per month and per year. The display wirelessly connects via a 900 MHz frequency and works up to 1000 feet (305 m). Actual range may depend on local conditions.</p> <p><b>Remote Monitoring</b></p> <p>There are a number of benefits to remote monitoring. A subscription to Fat Spaniel Technology allows a third party company to monitor the performance of your Skystream and communicate with a local dealer in the event there is a problem. Additionally, for states with "green tags" you could receive added revenue for each KWh your Skystream produces. Contact your dealer or Southwest Windpower directly for more information.</p>
	<p><b>USB Converter &amp; DataLogger Software</b></p> <p>The USB converter allows you to connect the remote display to your computer and monitor Skystream real time. Specialized software allows you to create your own power curves, monitor performance remotely and even download and transmit the latest software directly to your Skystream to maximize performance. To connect Skystream to your computer, you must also use the wireless remote.</p>
	<p><b>Battery Voltage Sensor</b></p> <p>The battery voltage sensor enables use of Skystream with battery based or battery backed systems. Sensor monitors battery voltage and sends charging information to Skystream by rapid frequency.</p>
	<p><b>Tower Adaptor</b></p> <p>The tower adaptor allows you to attach your Skystream to a tower constructed of 5 inch schedule 40 pipe. Nominal internal diameter of 5 inch (12.7 cm).</p>

Images shown are not to scale.

## 1-4 Skystream Project Preparation

There are several considerations before you begin the installation process of your Skystream. These considerations are more important if you intend to connect your machine to the electrical utility. Although Skystream is UL 1741 and IEEE 1547 certified, your local utility and zoning authority may require additional information prior to installation. This chapter will provide an overview of what to expect when working with your zoning authority and utility. Southwest Windpower has a number of resources that may assist you in the permitting and interconnection processes.

To learn more go to: [www.skystreamenergy.com](http://www.skystreamenergy.com)

### 1-4-1 Finding the Best Location for Your Skystream

We have worked at simplifying the installation process of Skystream, but each installation is likely to be different. Skystream may require a different tower depending on trees, obstructions and soil types.



**VERY IMPORTANT:** Proper siting is essential to a well performing wind generator.

The taller the tower, the more energy your Skystream will produce. But keep in mind, this will also increase the cost of the installation. It is extremely important to balance performance (tower height) to installed cost in order for you to achieve the lowest cost of energy and quickest payback. Also, keep in mind zoning regulations that may restrict the height of your tower. See section 1-4-4 regarding zoning.

**Our General Rule:** For optimal performance, Skystream should be 20 feet (7 m) above any surrounding object within a 250 foot (76 m) radius.

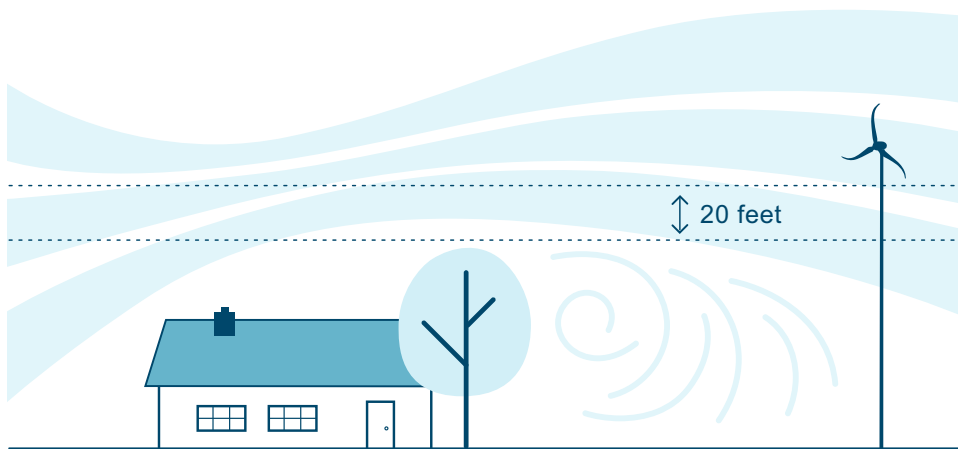

Fig. 1 Optimal Skystream location.



**TIP:** Your dealer can help you determine the best location for Skystream on your property.

### 1-4-2 Tower Types

Depending on your site needs, Skystream can be mounted on several different tower types as long as they meet the tower load specifications determined by Southwest Windpower and are certified by a Professional Engineer (PE). While a guyless monopole tower is the most desired tower type, it may be more expensive than some other options such as a guyed tower or latticed tower. You can find out more about available tower options provided by Southwest Windpower at: [www.skystreamenergy.com](http://www.skystreamenergy.com).

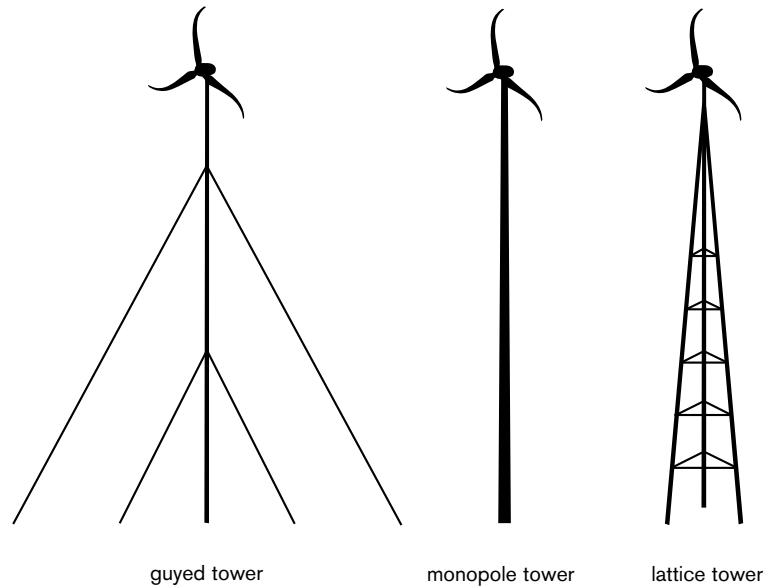

Fig. 2 Tower types

### 1-4-3 Working With Your Utility

Call your local electric utility, tell them your intentions and ask for their “**Interconnection Agreement**”. They should have one. Depending on your utility, the interconnection agreement may be one page or many. Keep in mind that small utility-connected solar and wind systems are relatively new industries and utility connection requests may be unfamiliar to them. If you are the first, realize the process may take longer. Southwest Windpower has people and tools that may assist in the process.

Your utility may request documentation demonstrating that Skystream is UL 1741 and IEEE 1547 certified. You can download the UL Certificate of Compliance at our website: [www.skystreamenergy.com](http://www.skystreamenergy.com)

 **TIP:** See our website: [www.skystreamenergy.com](http://www.skystreamenergy.com) for a sample interconnection agreement that may be used by a utility that has yet to establish a program.

### 1-4-4 Working With Your Local Zoning Authority

Like your utility, the local planning and zoning authority may or may not have experience with an individual installing a small wind generator at their home or small business. The most important issue is the height of the tower. Prior to purchasing your Skystream tower, check for local zoning limitations. Determine what your community allows for towers and determine if the height is appropriate. Specific data and statistics that may be required by your zoning authority can be found at [www.skystreamenergy.com](http://www.skystreamenergy.com).

## Two - Installation

Southwest Windpower designed the installation process of Skystream to be as easy as possible by minimizing the number of connections between the machine and circuit breaker. Depending on your local utility requirement, you may or may not need to install a separate disconnect and/or second meter.

You will notice the rotor shaft on Skystream is extremely difficult to turn. This is normal. As a safety precaution, the default position of Skystream is in brake mode when the inverter is disconnected from the utility-supplied power. The reason is if there is a fault in the utility line, Skystream must shut down to prevent back feeding of electricity into the line while it is being repaired.

### 2-1 Electrical

One of the most common causes of wind generator failures is a poor electrical connection. Be sure to follow the instructions and tighten all fasteners appropriately.

**IMPORTANT:** It is extremely important that the installation of your Skystream is done in accordance with local and national building codes as specified by the NEC, UBC (Uniform Building Code) or IBC (International Building Code). These codes will vary from city to city and country to country.

The AC input and AC output circuits are isolated from the enclosure. System grounding, if required by section 250 of NEC, ANSI/NFPA 70, is the responsibility of the installer.

### 2-1-1 Wiring

Skystream has a built-in utility-connected inverter compliant with UL 1741 and IEEE 1547. This means Skystream connects directly to your existing electrical system. **Appendix A** includes reference drawings for utility-supplied power interconnection of your Skystream generator. These drawings are for reference and may be modified for submittal and approval by your local authorities.

Refer to **Fig. 3** on following page for an overview of a typical residential Skystream wiring installation



**Warning:** For your safety, make sure power is turned off before working on any and all electrical connections.

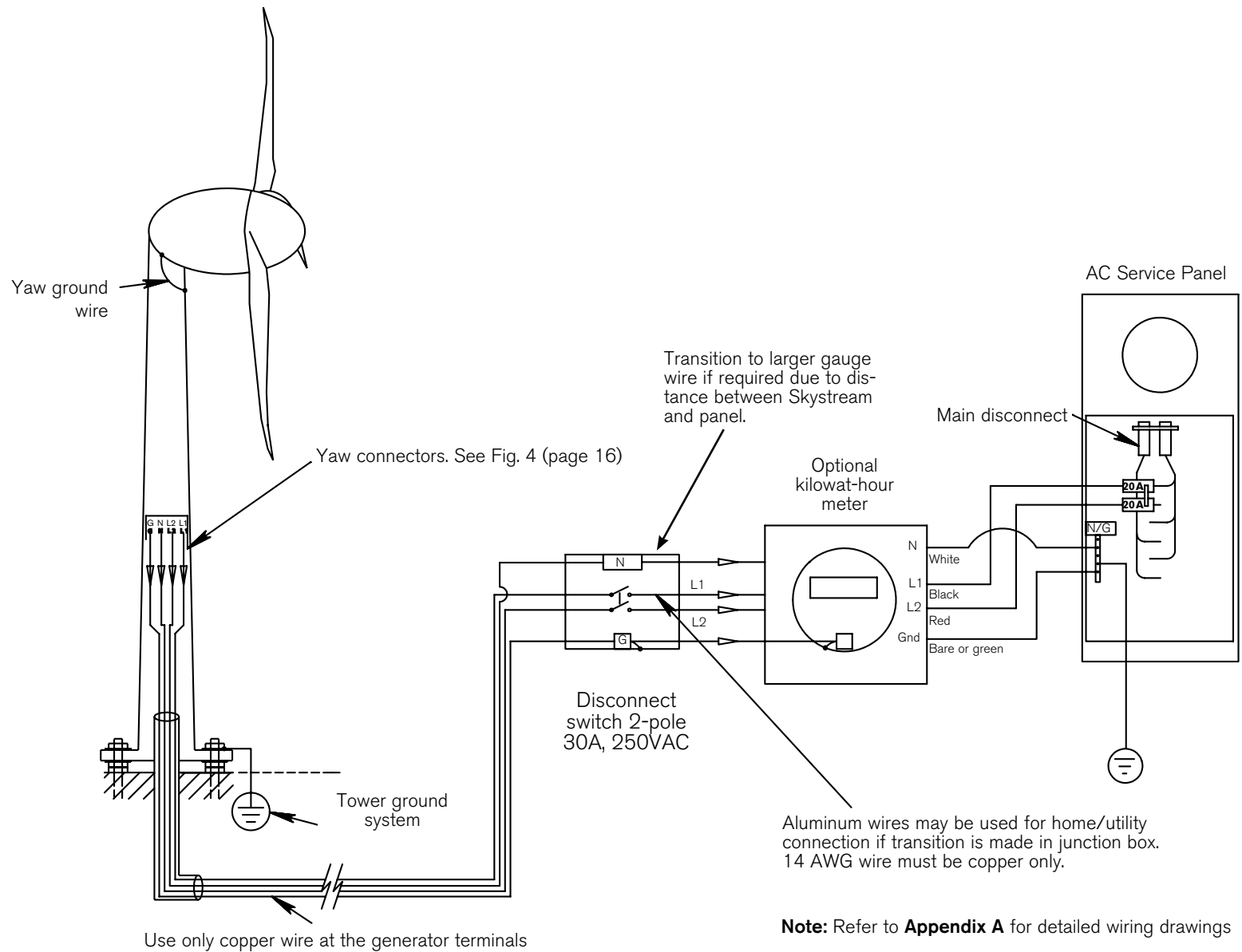

Fig. 3 Wiring diagram, 240V, 60Hz, split phase.

## 2-1-2 Electrical Connections

**CAUTION – Be sure power is turned off when making electrical connections.**

- Position Skystream on its side to access the wire terminals.
- Remove approximately 2 inches (5 cm) of protective sheathing from cable and strip approximately 0.375 inches (1 cm) of insulation off wire leads.
- Note the maximum wire size that can be connected directly to Skystream is #8 AWG. Refer to Wire Sizing Section of this manual for instructions on selecting correct size wire.
- Pass cable through strain relief cover so approximately 1 inch (2.5 cm) of cable sheath protrudes through as shown in **Fig. 4a**. Tighten strain relief clamp to secure cable.
- **120/240 V, 60 Hz, Split Phase and 120/208 V, 60 Hz, 3 Phase systems:** Connect the red, black and white wires to the corresponding color coded terminals on Skystream yaw. Connect green or bare copper wire to the green terminal. Tighten wire terminal screws to 20-25 inch-lbs (2.3-2.5 N-m). See **Fig. 4a**.
- **230 V, 50 Hz, 1 Phase systems:** Connect the brown, blue and green/yellow wires to the matching corresponding color coded terminals on Skystream yaw. There is no wire connection to bare yaw terminal as shown in Fig 4b. Tighten wire terminal screws to 20-25 inch-lbs (2.3-2.5 N-m).



**Caution:** Make sure AC power is switched "OFF" before proceeding with installation.

- **120 V, 60 Hz, 1 Phase Systems:** Connect the black and white wires to the corresponding color coded terminals on the Skystream yaw. Connect green or bare copper wire to green terminal. There is no wire connection to bare yaw terminal as shown in **Fig. 4c**.

Before attaching the strain relief cover, test the electrical connections by turning on power and measuring voltage at the yaw terminals. Additionally, with AC power switched on, wait 5-7 minutes and attempt to rotate the blade shaft. The shaft should be noticeably easier to rotate. Turn\* off power and Skystream should revert to "brake" mode. If Skystream fails this test, check all connections and repeat test. Test must be passed before proceeding.

- Turn power off and secure strain relief cover using four M5-0.8 x 12 socket head screws and split lockwashers. Use Loctite® 242 and torque screws to 20-25 inch-lbs (2.5 N-m).

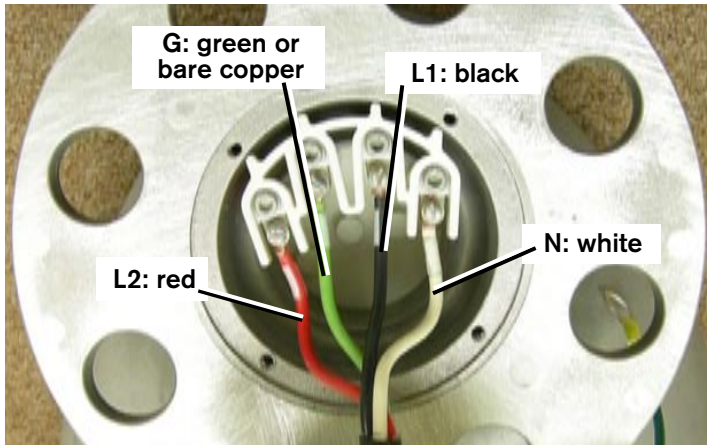



Fig. 4a Wire run to the yaw connection (120/240 V, 60Hz, Split Ph and 120/208V, 60 Hz, 3 Ph).

**Wiring Symbol Definitions - 120/240 V, 60 Hz, Split Phase and 120/208 V, 60 Hz, 3 Phase**

L1 = Line 1, AC Line Voltage, Black Wire (240V, 60 Hz, systems)  
 L2 = Line 2, AC Line Voltage, Red Wire (240V, 60 Hz, systems)  
 N = AC Neutral, White Wire, (240V, 60 Hz, systems)  
 G = Gnd. = AC Ground, Green or Bare Wire

 Indicates AC Ground

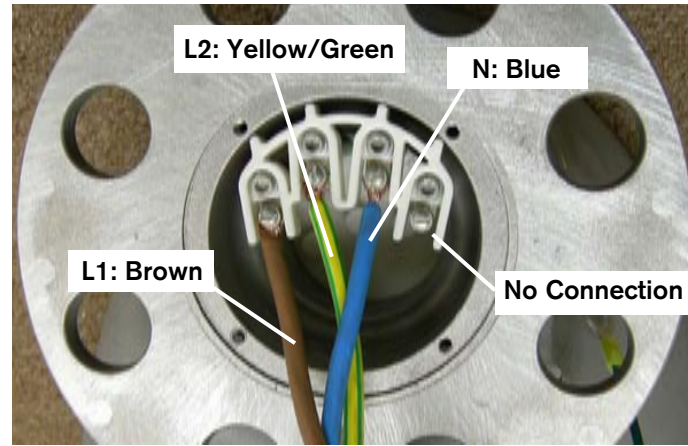



Fig. 4b Wire run to the yaw connection (230V, 50Hz, single phase).

**Wiring Symbol Definitions - 230 V, 50 Hz, Single Phase Systems**

L1 = Line 1, AC Line Voltage, Brown Wire (230V, 50 Hz, systems)  
 N = AC Neutral, Blue Wire, (230V, 50 Hz, systems)  
 G = Gnd. = AC Ground, Green/Yellow Wire

 Indicates AC Ground

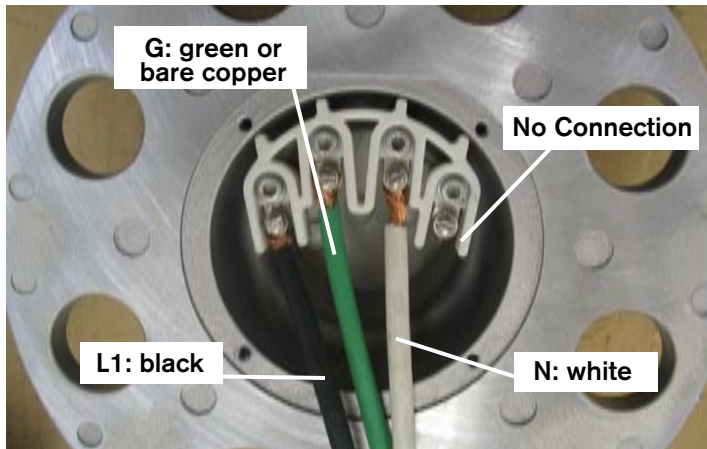



Fig. 4c Wire run to the yaw connection (120 V, 60 Hz, single phase).

**Wiring Symbol Definitions - 120 V, 60 Hz, Single Phase Systems**

L1 = Line 1, AC Line Voltage, Black Wire  
 N = AC Neutral, White Wire  
 G = AC Ground, Green or Bare Wire

 Indicates AC Ground



### 2-1-3 Wire Sizing

Measure distance from AC Service panel to Skystream including tower height. Refer to the Wire Size Table and based on system voltage and measured distance determine appropriate wire size.

The maximum wire size that can be connected to Skystream yaw is 8 AWG (10mm<sup>2</sup>) therefore if a larger wire size is required because of the installed distance, Southwest Windpower recommends installing a Power Disconnect Switch box close to the base of the tower and transitioning to the appropriate size wire. Refer to **Figs. 3, 4** and **Appendix A** for detailed information.

Battery charging systems may utilize smaller gauge wire than indicated in the Wire Size Table. Refer to diagrams in **Appendix A** for wire sizes. The smaller wires are based on allowing 4% voltage line loss for battery charging systems compared to 2% line losses indicated in the Wire Size Table.

### 2-1-4 Grounding

All electrical systems must be grounded in accordance with local and national standards. Grounding provides protection from electrical shock, voltage surges and static charge build up.

The figures in **Appendix A** provide information for grounding the tower and Skystream at the service panel by means of the ground lead coming from the yaw terminals of the turbine.

Appendix C provides information for grounding the tower according to the National Electrical Code (USA only). Information about grounding electrodes, grounding conductors, and connections is provided.

The turbine must be grounded to the tower as depicted in **Fig. 5**.

**Note:** The AC output neutral is NOT bonded to ground within Skystream. The AC neutral is bonded to ground at the AC service panel.

**The instructions in this section and Appendix A are provided as reference, local electrical codes and standards have precedence over these instructions.**

### 2-1-5 Fusing/Circuit Breaker

Skystream connects directly into your electrical panel. Wiring will vary with local zoning authority and utility. Refer to Appendix A for drawings for each voltage, frequency and phase configuration. Some installations will require a visible lockable disconnect switch located next to the electrical meter and/or at the base of the tower. The disconnect switch is utilized by your local utility in the event of a power outage to ensure no voltage is placed on the utility line during repair. Again, it is extremely important to install in accordance with local and national zoning regulations.

**Note:** Only 20 Amp circuit breakers may be used to connect Skystream to AC service panel. Refer to **Fig. 3**, wiring diagram.

Wire Size	Maximum Distance			
	120 V	120/208 V	230 V	120/240 V
4 AWG (25 mm <sup>2</sup> )	646 ft (197 m)	885 ft (270 m)	934 ft (285 m)	1017 ft (310 m)
6 AWG (16 mm <sup>2</sup> )	407 ft (124 m)	557 ft (170 m)	588 ft (179 m)	640 ft (195 m)
8 AWG (10 mm <sup>2</sup> )	256 ft (78 m)	351 ft (93.3 m)	371 ft (113m)	403 ft (123 m)
10 AWG (6 mm <sup>2</sup> )	161 ft (49 m)	220 ft (67.0 m)	232 ft (70.7m)	253 ft (77 m)
12 AWG (4 mm <sup>2</sup> )	101 ft (31 m)	139 ft (42.4 m)	146 ft (44.5)	159 ft (48.5 m)
14 AWG (2.5 mm <sup>2</sup> )	64 ft (20 m)	87 ft (26.5 m)	92 ft (28 m)	100 ft (30.5 m)

Use copper conductors only - Minimum wire temperature rating is 75° C (167°F). Distances and wire sizes are based on 1800 W power production and maximum 2% voltage line loss. Distances for 120 V system based on 3000 W power production and 8% voltage line loss.

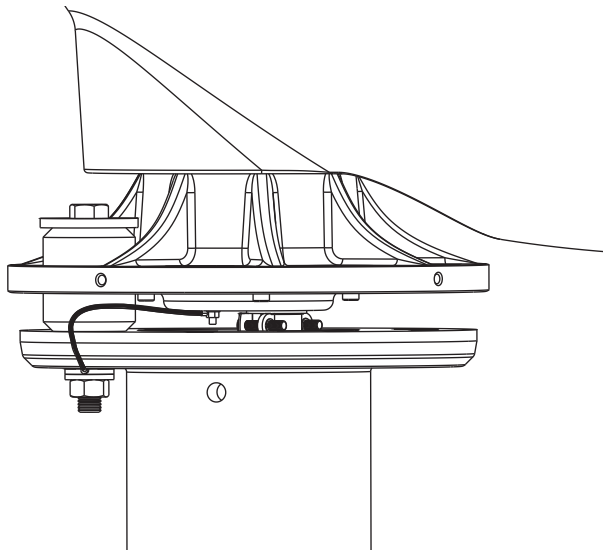

Fig. 5 Proper grounding of the yaw connection

### 2-1-6 Battery Charging

In addition to conventional grid connected systems, Skystream may be used with battery based systems or grid connected systems with battery back up. In the great majority of these applications the same Skystream is utilized as in grid connected system with the exception that a voltage sensor is required to transmit battery charge information to Skystream. This means that if in the future battery back up is no longer required or if connectivity to the grid is available the same Skystream may be utilized to supply power.

The following sections present the three most common Skystream battery charging or battery backup installation configurations. The best configuration for your particular application depends on a many factors including system type: battery based or battery backup, availability of existing equipment such as inverters, required voltage, wire run distance and of course cost.



### 2-1-6-1 Option A 120/240 Volt Skystream, Two Inverters

This option is a good choice for grid connected homes requiring battery backup and 240 volts. The same model Skystream is used for grid connected homes without battery backup therefore the system is adaptable if there is no longer a requirement for battery backup. The system is depicted below.

#### System Components:

- Skystream 3.7, Land unit part number 1-SSL-10-240, Marine unit part number 1-SSM-10-240
- Wireless Battery Voltage Sensor, part number 2-SSUP-102-02
- Wireless Display (optional), part number 2-SSUP-100-02
- Inverter (2 required), Southwest Windpower recommends Outback FX Series or Xantrex SW Series Inverters.

#### System Wiring

Wiring requirements for Battery Charging systems differ from Battery Backed - Grid Connected systems. Refer to **Appendix A** for specific wiring schematics.

Consult with your inverter supplier regarding inverter and battery installation. Due to the large number of inverter and battery system configurations it is not possible for Southwest Windpower to provide specific wiring instructions.

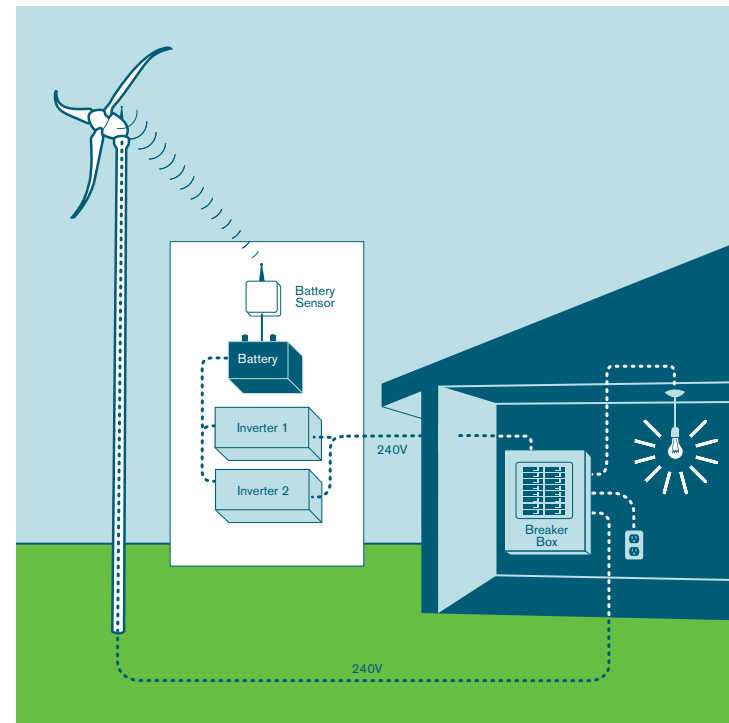

Fig. 6 Battery charging Option A

## 2-1-6-2 Option B 120/240 Volt Skystream with Transformer

This option is a good choice for systems with an existing inverter. It supports 240 volt loads and may be transitioned to a dedicated grid tied system if required in the future. The system differs from Option A in that a transformer takes the place of the second inverter. There is an inefficiency of approximately 20 watts associated with the transformer, however the inefficiency may be worth the reduced cost of the transformer compared to a second inverter.

### System Components:

- Skystream 3.7, Land unit part number 1-SSL-10-240, Marine unit part number 1-SSM-10-240
- Wireless Battery Voltage Sensor, part number 2-SSUP-102-02
- Wireless Display (optional), part number 2-SSUP-100-02
- Inverter (1 required), Southwest Windpower recommends Outback FX Series or Xantrex SW Series Inverters.
- Transformer, Southwest Windpower recommends the Outback PSX240 or Xantrex T24 transformers.

### System Wiring

Wiring requirements for Battery Charging systems differ from Battery Backed - Grid Connected systems. Refer to **Appendix A** for specific wiring schematics.

Consult with your inverter supplier regarding inverter and battery installation. Due to the large number of inverter and battery system configurations it is not possible for Southwest Windpower to provide specific wiring instructions.

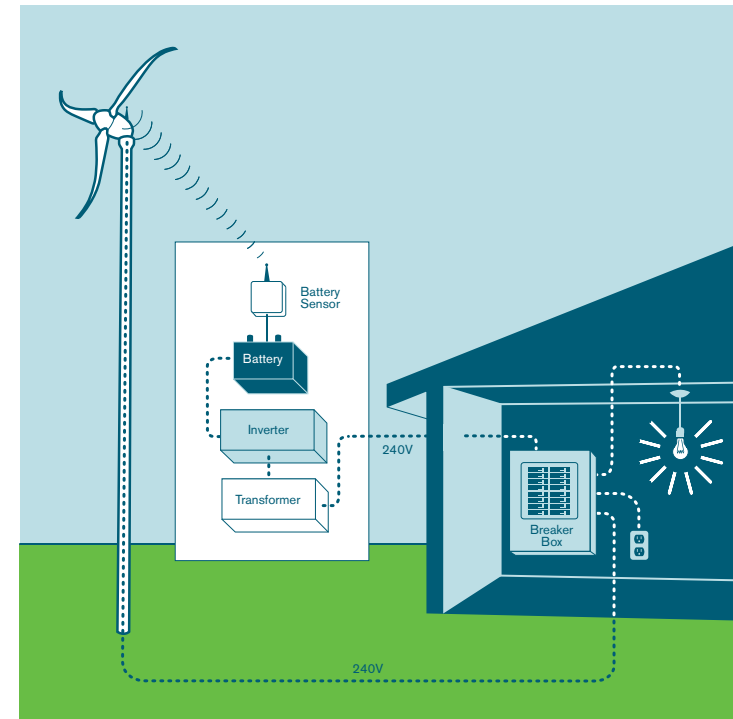

Fig. 7 Battery charging Option B

### 2-1-6-3 Option C 120 Volt Skystream, Single Inverter

This option is a good choice for homes that do not require 240 volt service. It is an economical system, however, it uses a different model Skystream than 240 volt systems, and therefore if conversion to 240 volt service is required in the future this system may not be a good choice.

And because this is strictly a 120 volt system if long wire runs are necessary Option B may be a more economical choice. Peak power in high winds is also reduced because this is a 120 volt system, therefore, this wind turbine may not be a good choice for high wind locations. The system is depicted below.

#### System Components

- Skystream 3.7, Land unit part number 1-SSL-10-120, Marine unit part number 1-SSM-10-120.
- Wireless Battery Voltage Sensor, part number 2-SSUP-102-02
- Wireless Display (optional), part number 2-SSUP-100-02
- Inverter (1 required), Southwest Windpower recommends Outback FX Series or Xantrex SW Series Inverters.

#### System Wiring

Wiring requirements for Battery Charging systems differ from Battery Backed - Grid Connected systems. Refer to **Appendix A** for specific wiring schematics.

Consult with your inverter supplier regarding inverter and battery installation. Due to the large number of inverter and battery system configurations it is not possible for Southwest Windpower to provide specific wiring instructions.

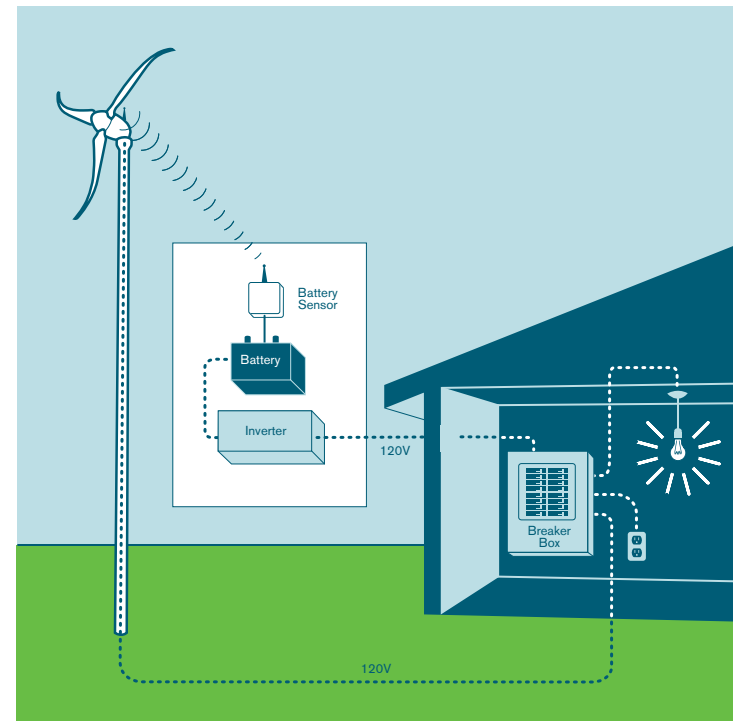

Fig. 8 Battery charging Option C

### 2-1-7 Battery Voltage Sensor Installation

The Battery Voltage Sensor is shown at the right. Customer is required to supply two battery connection terminals and color coded wire.

Install sensor as follows:

- The battery voltage sensor connector will accept #20 to #14 AWG wire. Use largest gauge wire compatible with battery connection terminals. Follow good practice and color code wires – red for positive, black for negative is typical.
- Determine sensor mounting location, maximum recommended wire length is 150 ft and 30 ft for #14 and #20 AWG wire respectively.
- Strip approximately 1/4" of insulation from wires and insert in green connector supplied with Battery Voltage Sensor. Tighten screws to secure wires. Correct wire locations (battery + and -) are indicated on Battery Voltage Sensor cover. Refer to **Fig. 9**.
- Strip insulation from other end of wires ends and install battery connection terminals following manufacturer's recommended procedure. Connect battery connection terminals to batteries.
- Insert green connector into Battery Voltage Sensor.

The sensor is now powered and ready for configuration with your system. Do not leave sensor connected to batteries without configuring sensor and Skystream for battery charging.



**IMPORTANT:** Battery voltage sensor and Skystream must be configured for battery charging or serious damage to batteries may result.



Fig. 9 Battery Sensor

## 2-2 Installing Skystream on a Tower

There are several types of towers that can be used with Skystream. It is essential that Skystream is installed on a properly engineered tower. One of the leading causes of wind generator failure is use on a poorly designed tower.

Southwest Windpower has made available various tower designs that meet our criteria. We have established a program allowing tower manufacturers to include their designs on Southwest Windpower's website list of recommended towers.

Regardless of the tower design and height you select, there are two critical areas that must be considered when selecting the tower. These are the stub tower height and blade clearance (see Fig. 10).



**IMPORTANT:** Southwest Windpower's Warranty is only extended to installations that are made on a properly engineered tower. Southwest Windpower reserves the right to deny any warranty claim in which an improperly designed tower is used.

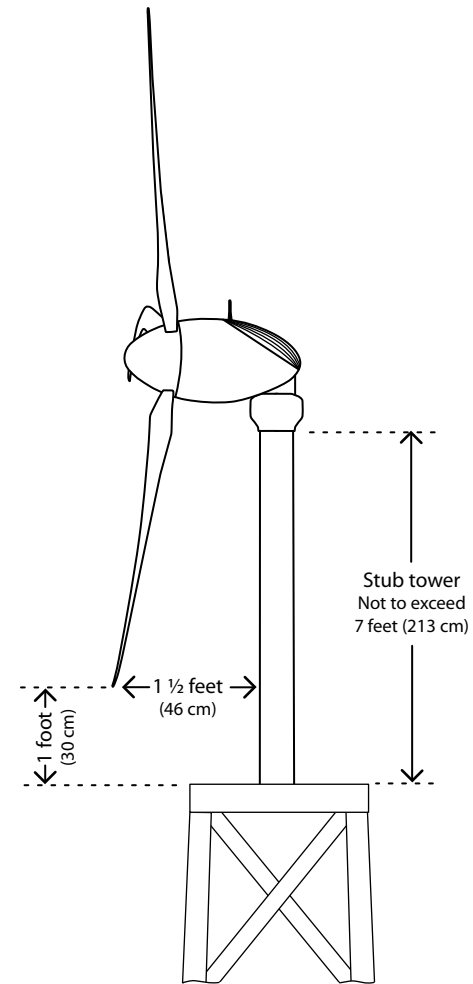

Fig. 10 Blade tip clearances

### 2-2-1 Mounting Skystream to the Tower

Refer to **Figs. 9-15** for visual aid.

**Note:** The following directions assume Skystream will be bolted to the tower on the ground and the tower tilted into position as in the case of the 33 Ft. tower. Alternately, Skystream may be hoisted to tower top using a crane in the case of larger towers that cannot be tilted into position. Instructions for hoisting Skystream are given below.



**Warning:** Working on towers is dangerous and should be left to professionals with proper safety equipment and training.

To ease mounting Skystream, support the upper end of the tower approximately 2-3 feet (0.6-1.0 m) above the ground.

- Install the vibration isolators on yaw flange as shown in **Fig. 11** (also see **Fig. 15**, page 26). Install snubbing washers and bolts in vibration isolators.

**Note:** The orientation of the vibration isolators is very important. Refer to **Fig. 15** (page 26).

- Using an appropriate lifting device and sling, lift Skystream and align vibration isolator bolts with holes in tower flange.
- Install nuts, flat washers and lock washer on bolts to secure Skystream to tower.
- Ground the turbine to the tower as depicted in **Fig. 5** and accompanying photographs.
- Torque vibration isolator bolts to 80 lb-ft (108 N-m) in two steps. First torque all bolts to 40 lb-ft (54 N-m) then to 80 lb-ft (108 N-m).
- Mount yaw shield halves using four M5 button head screws. See **Fig. 15** (page 26). Use Loctite® 242 supplied with Skystream.

**Note:** If you are using a tower that is not a tilt-up design, then the Skystream can be hoisted to the top of the tower.

- You will need a crane, or equivalent device, capable of hoisting 170 lbs (77 kg), and be able to reach the tower-top.
- The assembled Skystream can be hoisted to the top of the tower using a large width nylon strap. The nylon strap should be secured around the nacelle and cinched tight prior to hoisting.
- The Skystream can be hoisted with the rotor blades and hub already attached.
- The location of this strap is midway between the rotor blades and yaw, at the approximate balance point on the Skystream assembly. Do not stand under the Skystream while it is being raised.

### 2-3 Testing on the Ground

Though Skystream is thoroughly tested at the factory, it is very important to conduct one more test prior to erecting the tower. Skystream should be wired and mounted to the top of the tower. The blades should not be attached. To do this test, you must have all wires and breakers installed with at least one disconnect switch open (off).

#### 2-3-1 Electrical Tests

- Attempt to rotate the rotor shaft. It should be difficult to turn.
- Now turn on all power going to Skystream. Turn on all breakers, connect all switches and wait 5-7 minutes.
- Grab the rotor shaft again and try to spin it. If assembled correctly, it should spin easily.
- Before you go any further, turn the power off and disconnect any switches. Again, try spinning the shaft. It should be difficult to turn.
- Verify Skystream is grounded to tower by measuring resistance between Skystream nacelle and tower flange. Resistance =  $< 1$  ohm.

If Skystream does not spin freely after electrical test, then check for loose or disconnected wires. Repeat the test until you are successful.





Fig. 11 Placing vibration isolators



Fig. 12 Tightening bolts



Fig. 13 Grounding turbine to tower



Fig. 14 Ready to attach yaw shield

## 2-4 Blades, Nosecone and Antenna Assembly

Refer to **Fig. 16** (page 27) for visual aid.

The Skystream blades may be bolted to the blade hub and mounted on Skystream as a complete assembly by performing the following steps.

- Remove the blade mounting hub and plate from Skystream by “unscrewing” the hub while holding the rotor shaft stationary.
- Place a blade between the blade hub and blade mounting plate. Refer to **Fig. 16** (page 27) for proper orientation.  
**Note:** the blades may only be installed in one position due to the “triangular” boss cast into one side of the blade root (base).
- Loosely install the bolts, flat and lock washers for one blade leaving enough play so remaining blades can be installed.
- After all blades and bolts are loosely installed between blade hub and mounting plate, tighten bolts enough to clamp blades between hub and blade plate.
- Torque blade bolts to 50 lb-ft (68 N-m) in two steps. First torque all bolts to 25 lb-ft (34 N-m) then to 50 lb-ft (68 N-m).
- Blade assembly may now be mounted on Skystream. Slide blade assembly completely onto shaft. With assembly completely on shaft, large mounting nut can be started on shaft threads.
- Completely “spin” on blade assembly. Securely tighten blade assembly by holding blades and tightening “flat” on rotor shaft.  
**Note:** the blade assembly is self-tightening in operation; however it should be securely tightened during assembly (200lb-ft).
- Install nosecone with three M6-1.0x12 socket head bolts. Use Loctite® 242 supplied with Skystream.
- Install RF Antenna on matching fitting on top of Skystream. Finger-tight is sufficient.

### Important: Do Not Forget to install RF Antenna

Even if you have not purchased the optional remote display, the RF antenna may be used by service personnel to diagnose, troubleshoot or upgrade your Skystream without removing it from the tower.

**IMPORTANT:** Liberally lubricate blade and vibration mounting nuts and bolts with oil. Fasteners have extra plating to prevent corrosion and lubrication will ease assembly and disassembly.

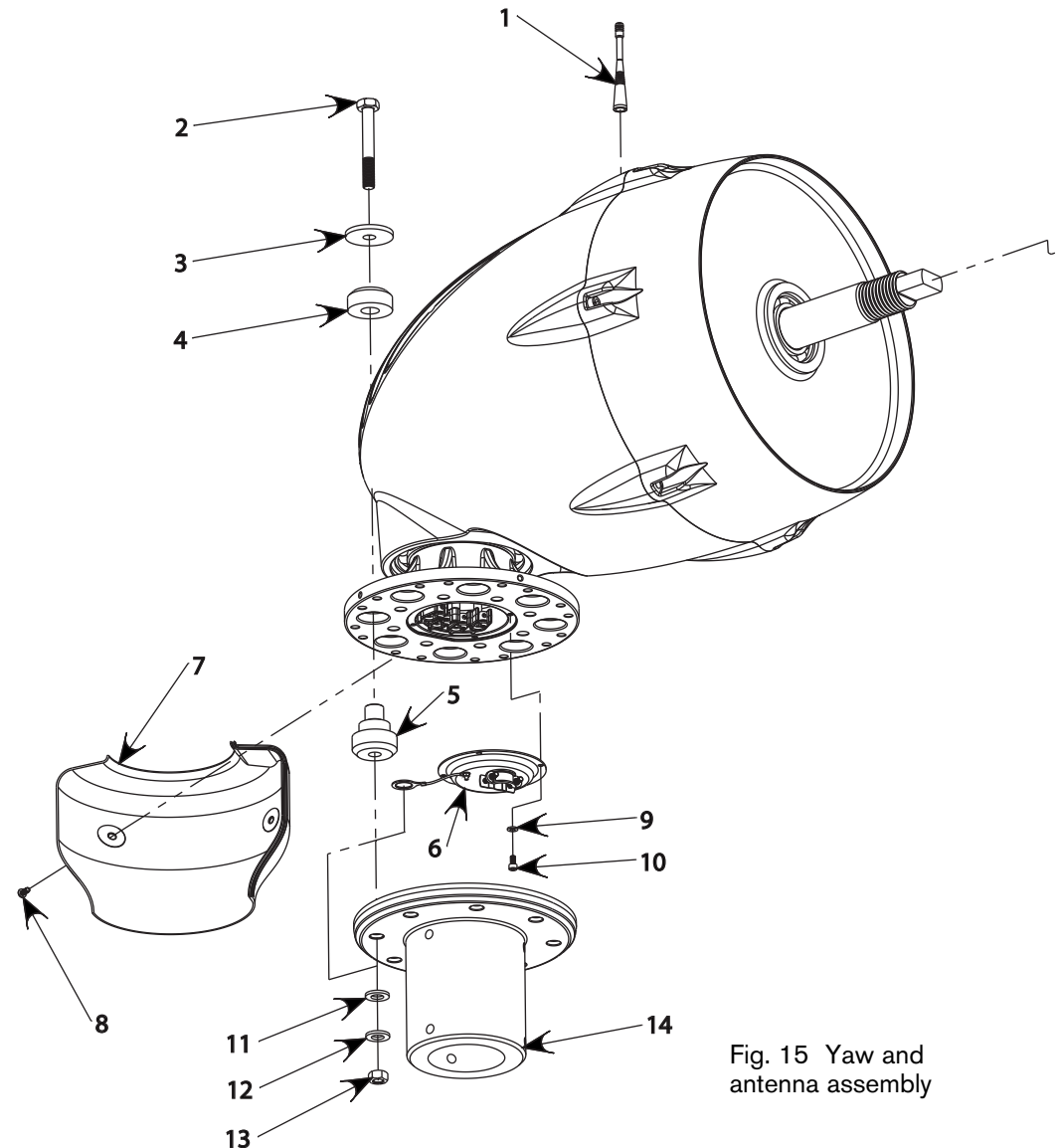

Fig. 15 Yaw and antenna assembly

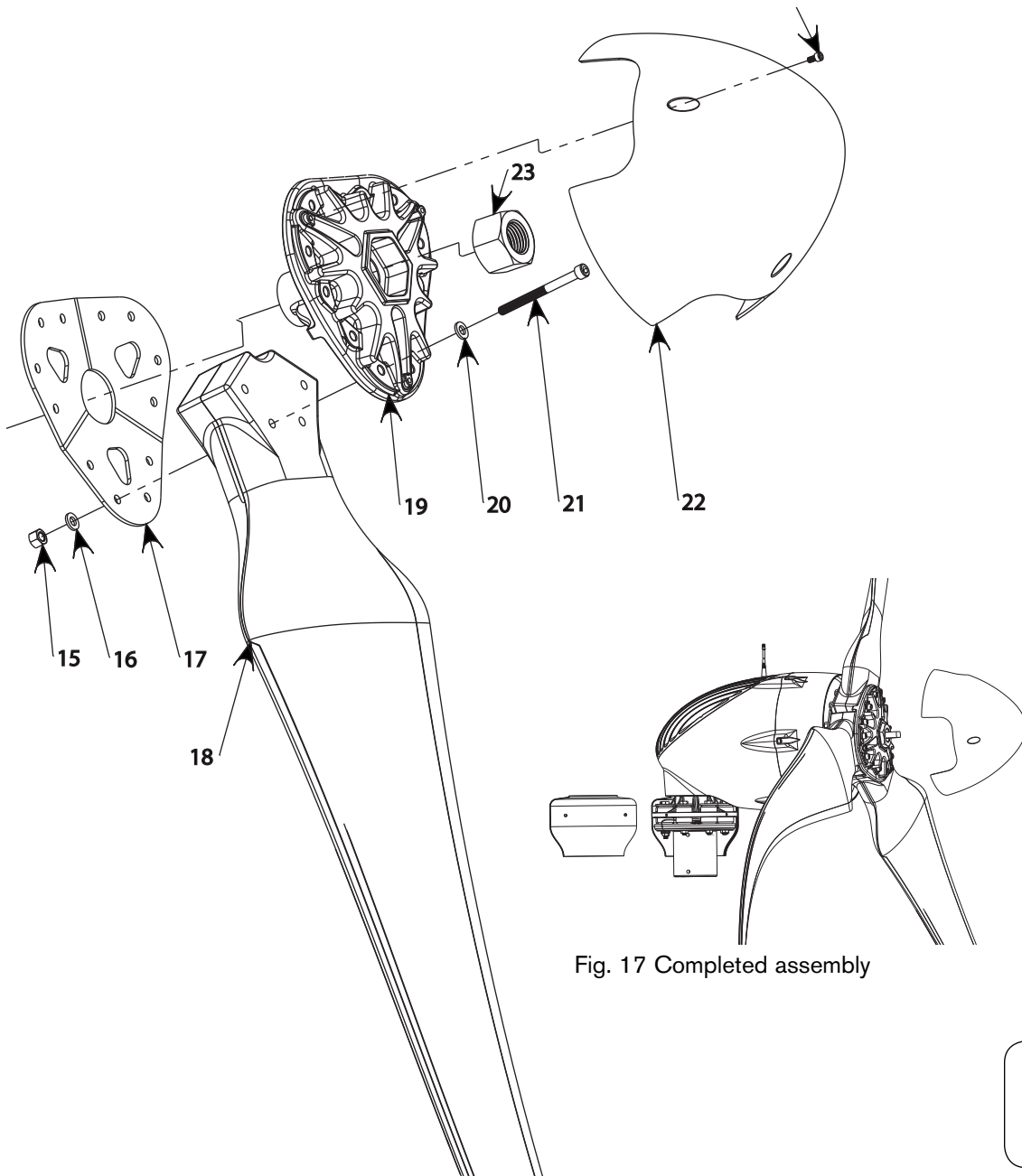

Fig. 16 Blade and nosecone assembly

Fig. 17 Completed assembly

**Yaw Components**

#	DESCRIPTION	QTY.
1	RF Antenna	1
2	M12 x 1.75 x 90mm Hex Bolt Grade 10.9	8
3	Snubbing Washer	8
4, 5	Vibration Isolation Ring (4) and Bushing (5)	8
6	Strain Relief Cover Assembly	1
7	Shield	2
8	M5 x .8 x 12mm Button Head grade 8.8	4
9	M5 Lock Washer A2 stainless steel	4
10	M5 x .8 x 12mm Bolt SHCS grade 8.8	4
11	Flat Washer (M12) A2 stainless steel	8
12	Lock Washer (M12) A2 stainless steel	8
13	M12 x 1.75 Nut grade 10.9	8
14	5" Tower Insert (optional)	1

**Blade Components**

#	DESCRIPTION	QTY.
15	M10 x 1.5 Nut grade 10.9	12
16	Lock Washer (M10) A2 stainless steel	12
17	Blade Plate	1
18	Blade	3
19	Blade Hub	1
20	Flat Washer (M10) A2 stainless steel	12
21	M10 x 1.5 x 120mm Bolt SHCS grade 10.9	12
22	Nose Cone	1
23	Hub Retaining Nut grade 10.9	1
24	M6 x 1 x 12mm Bolt SHCS grade 8.8	3

**!** **IMPORTANT:** Liberally lubricate blade and vibration mounting nuts and bolts with oil. Fasteners have extra plating to prevent corrosion and lubrication will ease assembly and disassembly.

## Three - Operation & Maintenance

### 3-1 Skystream 3.7™ Key Operating Characteristics

#### Procedure for Starting and Stopping Skystream

The procedure to start and stop the Skystream is at the dedicated Skystream breaker on the main electrical panel. The Skystream is turned on by switching the breaker “ON”, thereby connecting the Skystream to the electrical grid. After a five minute delay, the Skystream will release the internal brake, and begin producing electricity (when there are sufficient winds). The procedure for turning off the Skystream is to switch the electrical breaker to “OFF”, thereby disconnecting the Skystream from the electrical grid. The Skystream can be turned off, at any time, for any reason. When the Skystream is “OFF”, there is no live electrical wires between the main electrical panel and the Skystream.



**Warning:** Power to Skystream MUST BE TURNED OFF prior to servicing

The Skystream 3.7 operates by converting the kinetic energy of the wind into rotational motion that turns an alternator and ultimately produces usable electric power. In actuality this is a great over simplification of Skystream's operation since it must very precisely match the frequency and voltage of the electricity supplied by the local utility company in order to power your home and its appliances. Additionally, Skystream monitors and adjusts its performance to provide safe operation and extract the maximum energy from even low speed winds.

Skystream will begin producing power in a wind of approximately 8 mph (3.5 m/sec). At that speed the blades will rotate at approximately 120 rpm. Once it has started producing power, it will continue to produce power at lower speeds down to 80 rpm and less than 3 m/s. As the wind speed increases the blade speed will also increase. At about 20 mph (9 m/sec) the blades achieves a rotational speed of 330 rpm. This is Skystream's rated speed. Should the wind speed increase above 20 mph the blade speed will remain essentially fixed at 330 rpm.

If a condition occurs that causes the rotational speed to exceed 360 rpm, Skystream will shut down for approximately 10 minutes after which it will resume normal operation unless a fault is detected causing it to remain shut down. This is an unlikely scenario that should never occur in normal operation. It is important to set the elevation for the turbine to operate correctly. If it is not set, the turbine may experience premature shut downs.

If a wind gust exceeds 56 mph (25 m/s), then the Skystream will shut-down for 1 hour. After 1 hour, the Skystream will turn back on, and resume normal charging. If the wind is still above 56 mph (25 m/s), then the Skystream will shutdown for another hour.

In addition to adjusting its operation in response to wind conditions Skystream also monitors the electrical utility grid and its own internal health. Should the electric utility voltage or frequency differ from Skystream's voltage, for example due to a power failure, Skystream will disconnect from the grid and enter a “braked mode”. While in this mode the blades are held stationary while the Skystream monitors the utility power. If Skystream determines that the power has returned to within specification, it will re-connect to the grid and resume normal operation. This is the same cycle that occurs when Skystream is initially powered.

Additionally, should Skystream determine an internal fault exists it will execute an emergency shutdown – an E-stop. An E-stop will only take place if a severe fault that requires servicing internal components has occurred. For that reason resetting an E-stop requires gaining access to the interior of Skystream. It cannot be reset from the ground.

**As a final note, Skystream is factory configured for operation up to 3,300 feet (1000 m) above sea level. If your installation exceeds this elevation please consult Southwest Windpower technical service for assistance in resetting the configurations for your elevation.**

### 3-2 Electronic Stall Regulation

The Skystream 3.7 has the ability to adjust the rotational speed of its blades or even stop the blades if required by ambient conditions. This referred to as Stall Control and it is accomplished by adjusting the current draw from the alternator. The higher the current draw the greater the electromagnetic torque applied to the rotor and if enough torque is applied the blades will slow or even stop. In simple terms the inverter is demanding more power than the available wind can provide thus causing the blade rotational speed to decrease.

As a safety feature the alternator is capable of producing approximately five times the torque required to control the turbine. This extra available power means that even if segments of the alternator windings are damaged there is still sufficient torque to stop the turbine.

While Skystream is connected to the utility grid it constantly monitors that all conditions, for example grid voltage and frequency, are within limits. If the inverter determines that all operating conditions are within limits, it opens three Normally Closed (NC) relays, RL1, 2 and 3, removing the short from the alternator windings and allowing the blades to spin freely. Only then will it operate the DPDT Grid Relay RL\_G to allow the inverter to export power to the grid. Refer to the Skystream Block Diagram in Appendix A. Should the inverter sense an abnormal condition, for example high current in the alternator windings by means of the current sensors on the relay board it will close relays RL1, 2, and 3 thereby stopping the turbine. In turn, the DPDT Relay RL\_G will be operated to the position where the inverter power exporting circuitry is disconnected from the grid.

### 3-3 Redundant Relay Switch Control

As a redundant measure of safety to guarantee stopping the turbine in case of a winding fault or a lost connection to the alternator; there are seven connections to the alternator windings, but only three are necessary to control or stop the turbine. And as a final measure of safety, if the inverter is unable to control the rotational speed and Skystream exceeds approximately 400 rpm, the rectified voltage will exceed the Zener (Z) voltage on the relay board, causing the latching relay (RL4) to open. This will cause the relays RL1, 2, and 3 to close and apply all the available electromechanical torque to the rotor, stopping Skystream completely. The inverter power path will also be disconnected from the grid by means of relay RL\_G. This is the final level of control and is only applied when all other methods of control have failed. As such, once set, (latched) RL4 may only be reset by gaining internal access to Skystream – it cannot be reset via the Remote Display.



**Warning:** Power to Skystream MUST BE  
TURNED OFF prior to servicing

### 3-4 Shutting Down the Skystream for Maintenance

Power to Skystream MUST be turned off prior to servicing. Turn off power by opening the disconnect switch at the base of the tower, if available, or by opening the appropriate circuit breakers in the main service panel.

Turning off the power accomplishes two objectives: removal of the electrical shock hazard and locking the Skystream rotor by causing the inverter to close relays RL1, RL2 and RL3 and thereby shorting the alternator windings as described in Section 3 -2 Electronic Stall Regulation. It also disconnects the inverter power path from the grid by means of relay RL\_G.

The Skystream rotor will remain locked in this manner up to any speed within the IEC Class II regime (less than 140 mph or 62.5 m/s). Refer to Section 3 -1 Skystream Key Operating Characteristics for a description of the wind speed conditions that may cause Skystream to shut down.

#### Maintenance and Inspection

The Skystream is designed for 20 years of maintenance-free operation. All bearings and components were designed for a 20 year life at a site with an average annual wind speed of 19 mph (8.5 m/s). This type of site corresponds to a an IEC wind class II, under the IEC 61400-2 Small Wind Turbine Safety Standard.

#### Yearly Inspection

Although the Skystream is designed to be maintenance-free for 20 years, the Skystream owner should perform the following yearly inspections. The yearly inspection can be performed without lowering the tower, or otherwise gaining access to the turbine. The results from this yearly inspection should be written in a Skystream logbook.

While the turbine is operating in moderate winds, listen for any abnormal noises. After the first year of operation, you should be aware of the normal operating sounds from the Skystream. Normal noises include aerodynamic swishing, and the humming of the power electronics. If you notice any abnormal sounds, then record your observations in your Skystream logbook, and then call Southwest Windpower Technical Support.

The second part of the yearly inspection is to make detailed observations of the Skystream from the ground. Shut off the Skystream by disconnecting the Skystream from the grid, by turning the breaker to “OFF”, at the main electrical panel (see “Procedure for Starting and Stopping Skystream”). Turning off the Skystream will cause the blades to stop or spin very slowly in all wind speeds. With a pair of binoculars take very careful observations of the Skystream. Look for any problems with the blades such as cracks, or damage to the edges of the rotor blade. Look at the face and nacelle of the Skystream and note any potential damage. If you notice any damage during your yearly inspection, then write down your observations in your Skystream Logbook, and call Southwest Windpower Technical Support.

#### Turbine Access

In the event you have a need to gain access to the Skystream, for whatever reason, then the following procedures should be followed. Turn off the Skystream by disconnecting the Skystream from the electrical grid (see “Procedure for Starting and Stopping Skystream”). This is done at the dedicated Skystream electrical breaker located at the main electrical panel. This disconnect procedure will both stop the rotor, and disconnect the grid power to the Skystream, thereby making it safe to work on.



**Warning:** Prior to lowering or gaining access to Skystream with a man-lift, follow the procedure for the proper shutdown of the wind turbine. DO NOT work on Skystream if it is connected to the grid.

Be sure the Skystream is shutdown before proceeding any further. If you have a tilt-up tower, then lower the tower following the procedure for your particular tower. Rest the tower on a few supports before it gets to the ground. There is not a need to lock the rotor and yaw prior to working on the Skystream if it was lowered to the ground on a tilt-up tower.

If you are gaining access to the tower through the use of a man-lift, or equivalent, then it is important to lock the rotor and yaw prior to working on the Skystream at the top of the tower. This can be done by tightly tying a rope around the rotor blades and tower.

One such method for doing this is to tie a clove-hitch, or equivalent, around the tower, and then wrap the rope ends around the blades and tie together with a square knot. This will prevent the Skystream rotor blades from spinning, and the nacelle from yawing, while you are working on the unit on the tower-top.

**The following items should be checked while you have access to the Skystream:**

- Remove the yaw shield, and wipe off any grease that may have seeped from the yaw bearing.
- Verify the yaw bearing snap ring is still properly seated in the snap ring groove within the nacelle. (this is the spiral ring located just below the yaw bearing).
- Check the tightness of the (8) yaw bolts with a torque wrench. All yaw bolts should be torqued to 80 ft-lbs (108 N-m).
- Reinstall the yaw shield and secure the fasteners using Loctite 242 (i.e. removable blue threadlocker).
- Check tightness of blade bolts with torque wrench. All blade bolts should be torqued to 50 ft-lbs (68 N-m).
- Clean the rotor blades with a mild soap and water. Remove as much of the dead bug matter as possible from the blades.
- Look for any problems with the blades such as cracks, or damage to the edges of the rotor blade.
- Inspect the face, nacelle, and the rest of the Skystream and note any potential damage or problem.
- If you notice any damage or problem during your inspection, then write down your observations in your Skystream Logbook, and call Southwest Windpower Technical Support.

If you are using a tilt-up tower, then raise the tower following the instructions for your tower. If you are at the tower-top in a man-lift, then remove the rope tying the rotor blades to the tower, prior to being lowered back to the ground. Check that the tower is properly secured to the foundation.

Turn on the Skystream by switching the dedicated Skystream breaker to "ON", at the main electrical panel (see "Procedure for Starting and Stopping Skystream"). After a five minute delay, the Skystream internal brake will release, and then the blades will be free to rotate. The Skystream will then be back online and ready to produce electricity from the wind."

### **3-5 Frequently Asked Questions**

#### **1) What happens if I lose power from my utility company?**

If there is a power outage the Skystream will shut down within one second. It will resume normal operation when power is restored. There are many safety requirements of a utility-tied inverter. The Skystream meets all of these requirements per UL 1741.

#### **2) Does the Skystream have lightning protection?**

Yes, the Skystream has lightning protection. The Skystream can handle 6000 Volts as required by UL 1741. If you live in a lightning prone area SWWP recommends an additional lightning arrestor at the base of the tower.

#### **3) What should I do if I'm expecting a severe storm?**

The Skystream is designed for very high winds, but it is always a good idea to shut Skystream down if there is going to be a severe storm to protect against any flying debris.

#### **4) How do I shut down Skystream?**

To turn off Skystream all you need to do is turn off the breaker Skystream is connected to. This will cause NO damage to the unit.

#### **5) Can I leave Skystream unattended?**

Yes, the Skystream is designed to operate without any user input. If there is any fault it will shut down on its own.

#### **6) What do I do if Skystream is facing upwind even though there is a strong wind?**

If the Skystream is not tracking correctly, you should check to see if the tower is level.

#### **7) When should I contact an authorized service technician?**

- a. If there is any unusual vibration coming from Skystream.
- b. If you hear any noise that sounds like mechanical interference.
- c. If the Skystream is connected to the utility power (i.e. all breakers and disconnects are turned on), the wind is blowing, but the Skystream is not turning very fast.

#### **8) Can I mount Skystream to my roof?**

Roof and building mount is not recommended. Because of the size and weight of the wind generator, Skystream needs to be mounted on a PE certified tower to ensure the quietest and safest system. Roof mounting will invalidate the warranty.

#### **9) What should I do if ice forms on Skystream blades?**

To avoid the possibility of injury from ice breaking loose from the blades and injuring anyone, Skystream should be turned OFF if ice accumulates on the blades.





# SKYSTREAM 3.7™

## APPENDIX A ELECTRICAL DIAGRAMS

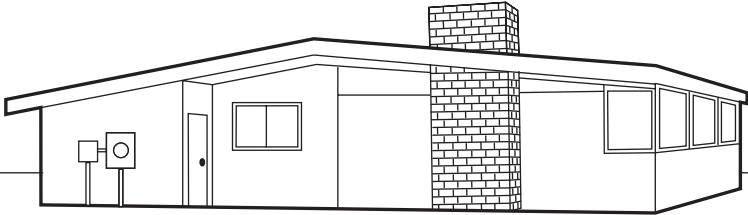
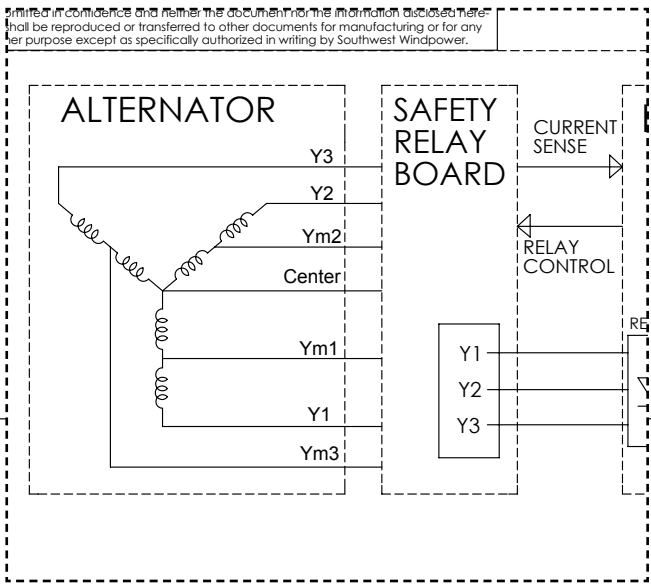
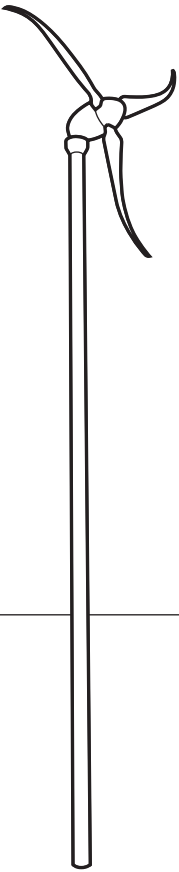

Southwest Windpower, Inc.  
1801 West Route 66  
Flagstaff, Arizona 86001  
Phone: 928.779.9463  
Fax: 928.779.1485  
[www.skystreamenergy.com](http://www.skystreamenergy.com)

MADE IN THE **USA** © June 2007 Southwest Windpower, Inc.  
All Rights Reserved.

# Skystream 3.7 Owner's Manual

## Appendix A: Electrical Diagrams

- 1) **GRID CONNECTION OPTION A:**  
120/240 V, 60 Hz, Split Phase, Junction Box at Tower Base \_\_\_\_\_ **3**
- 2) **GRID CONNECTION OPTION B:**  
120/240 V, 60 Hz, Split Phase, Without Junction Box at Tower Base \_\_\_\_\_ **4**
- 3) **GRID CONNECTION OPTION C:**  
120/208 V, 60 Hz, 3 Phase, Junction Box at Tower Base \_\_\_\_\_ **5**
- 4) **GRID CONNECTION OPTION D:**  
120/208 V, 60 Hz, 3 Phase, Without Junction Box at Tower Base \_\_\_\_\_ **6**
- 5) **GRID CONNECTION OPTION E:**  
230 V, 50 Hz, 1 Phase, Junction Box at Tower Base \_\_\_\_\_ **7**
- 6) **BATTERY CHARGING OPTION A:**  
120/240 V Battery Charging System Using Dual Inverters \_\_\_\_\_ **8**
- 7) **BATTERY CHARGING OPTION B:**  
120/240 V Battery Charging System Using Autotransformer and Inverter \_\_\_\_\_ **9**
- 8) **BATTERY CHARGING OPTION C:**  
120 V Battery Charging System Using Single Inverter \_\_\_\_\_ **10**
- 9) **BATTERY CHARGING OPTION D:**  
230 V, 1 Phase, Junction Box at Tower \_\_\_\_\_ **11**
- 10) **BATTERY CHARGING, GRID CONNECTED OPTION A:**  
120/240 V Battery Charging, Grid Connected Using Dual Inverters \_\_\_\_\_ **12**
- 11) **BATTERY CHARGING, GRID CONNECTED OPTION B:**  
120/240 V Battery Charging, Grid Connected Using Autotransformer and Inverter \_\_\_\_\_ **13**
- 12) **BATTERY CHARGING, GRID CONNECTED OPTION C:**  
120 V Battery Charging, Grid Connected Using Single Inverter \_\_\_\_\_ **14**
- 13) **SKYSTREAM BLOCK DIAGRAM** \_\_\_\_\_ **15**

Fig. 1. Grid Connection Option A: 120/240 V, 60 Hz, Split Phase, Junction Box at Tower Base

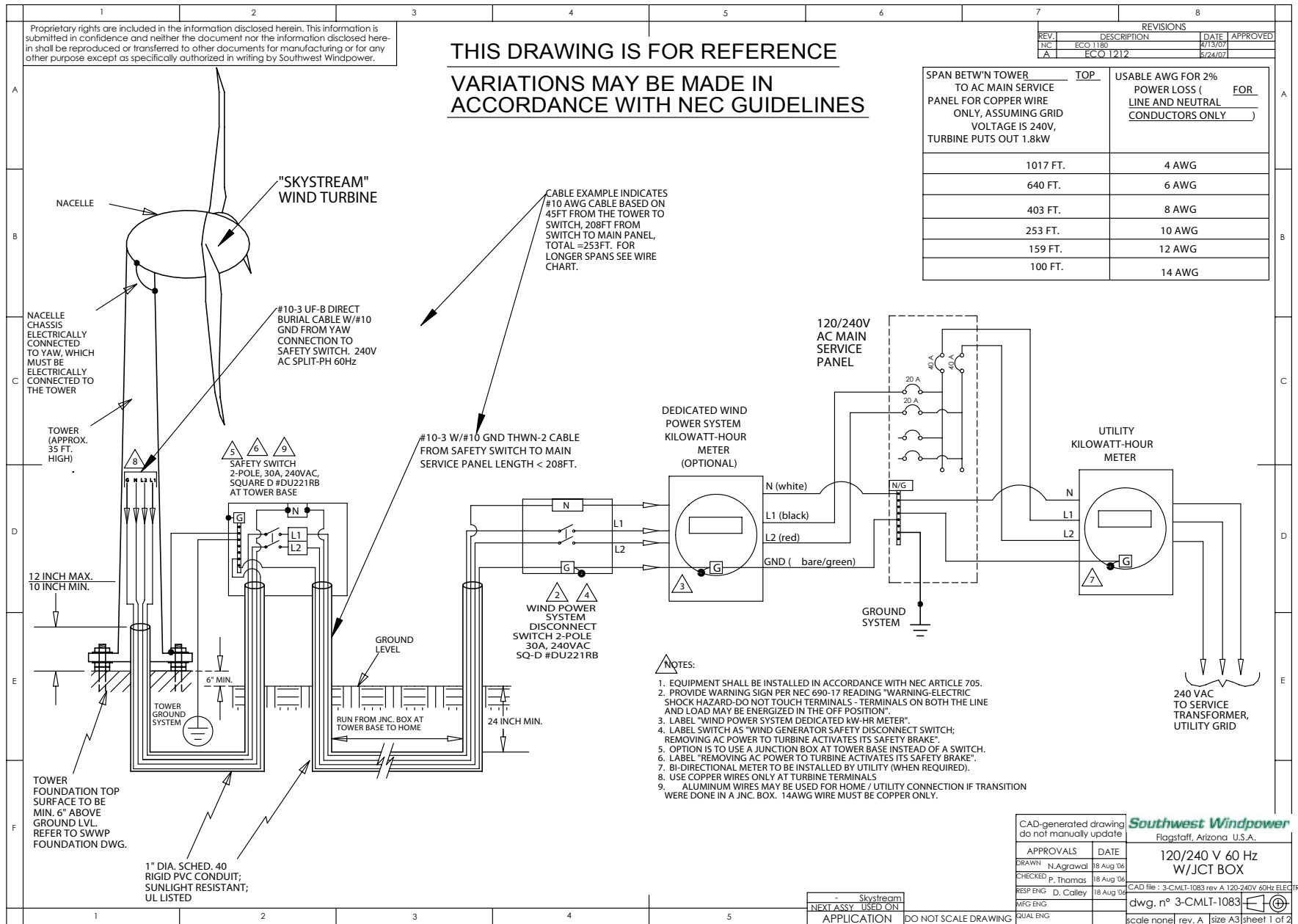

Fig 2. Grid Connection Option B: 120/240 V, 60 Hz, Split Phase, Without Junction Box at Tower Base

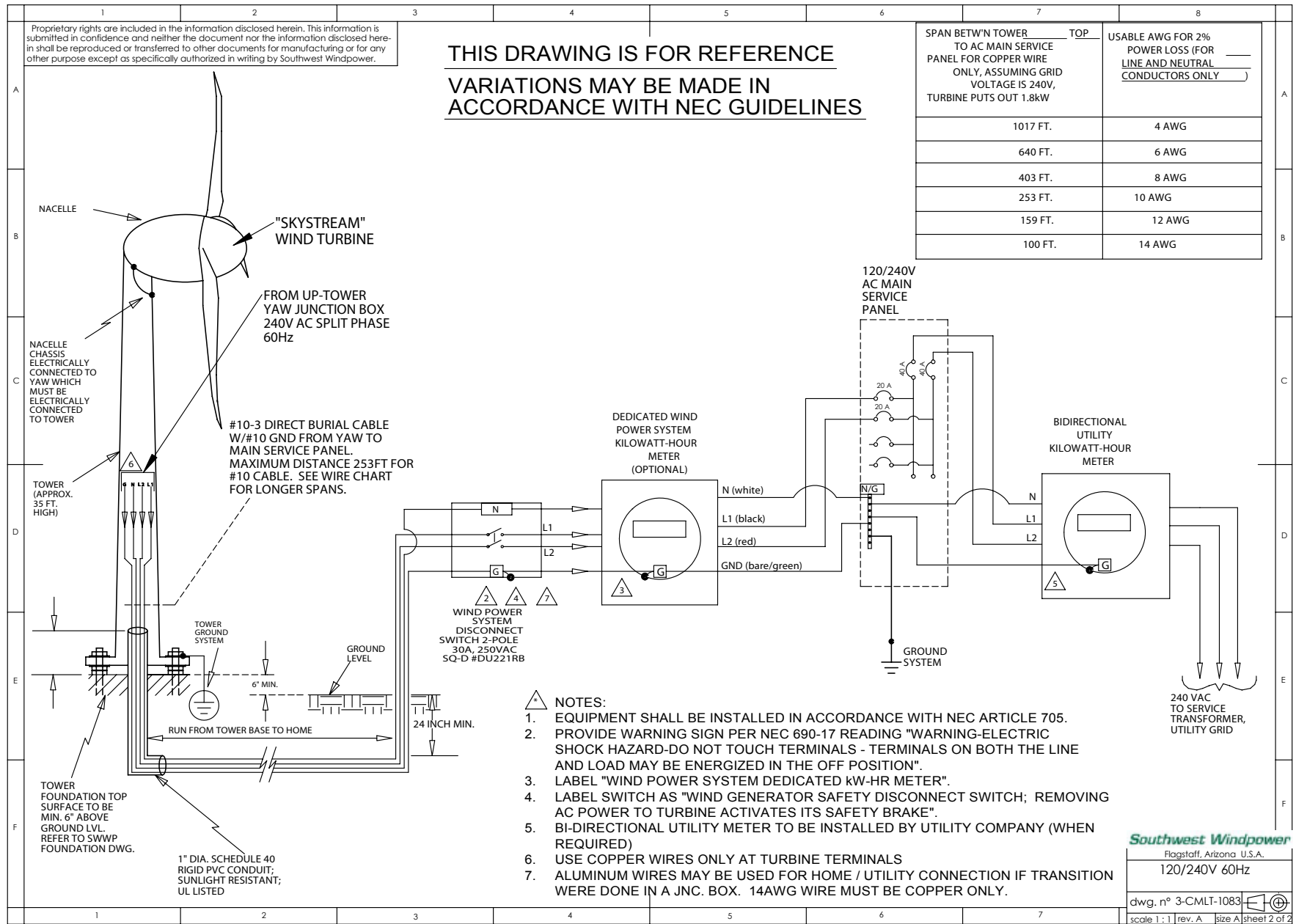

Fig. 3. Grid Connection Option C: 120/208 V, 60 Hz, 3 Phase, Junction Box at Tower Base

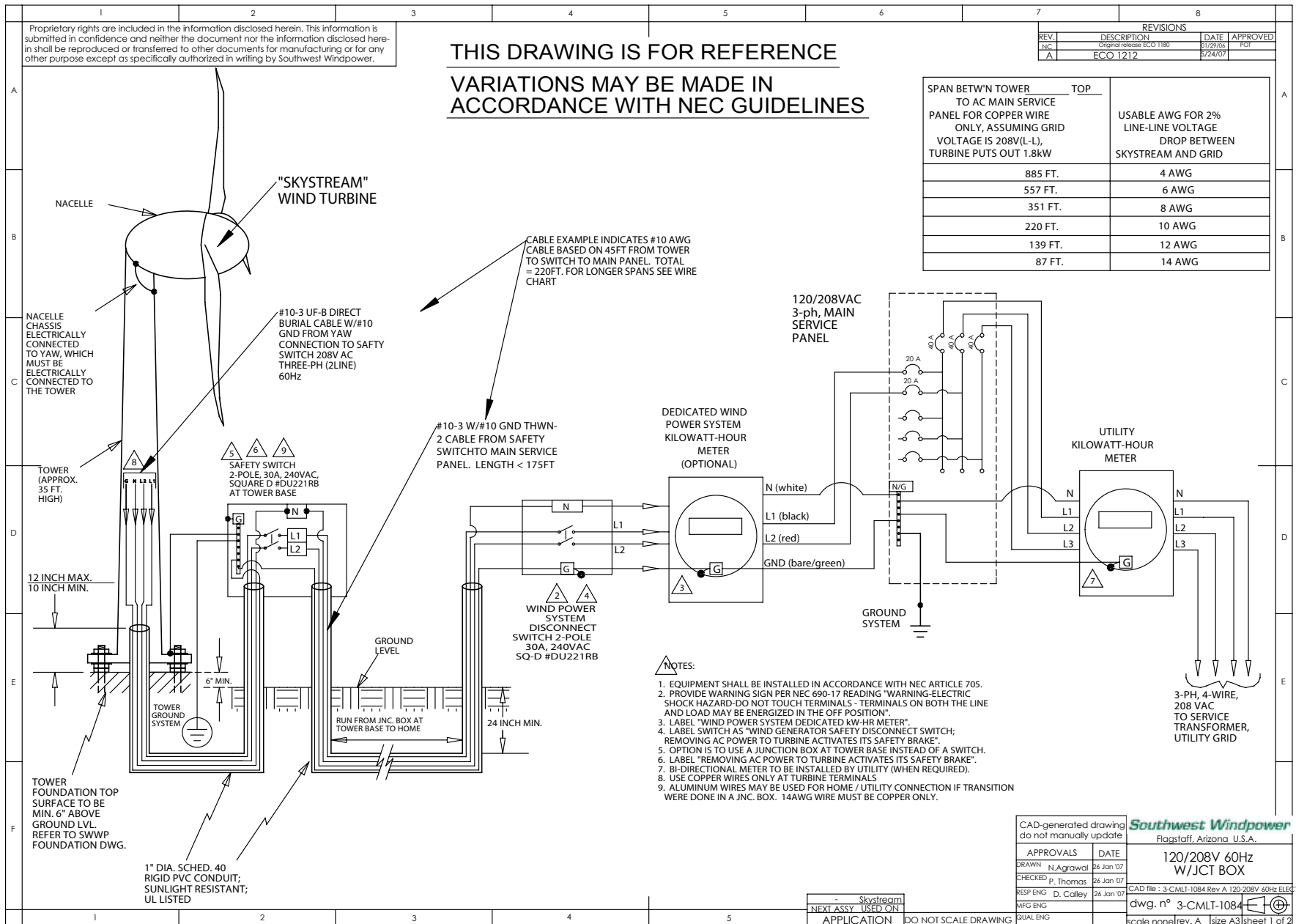

Fig. 4. Grid Connection Option D: 120/208 V, 60 Hz, 3 Phase, Without Junction Box at Tower Base

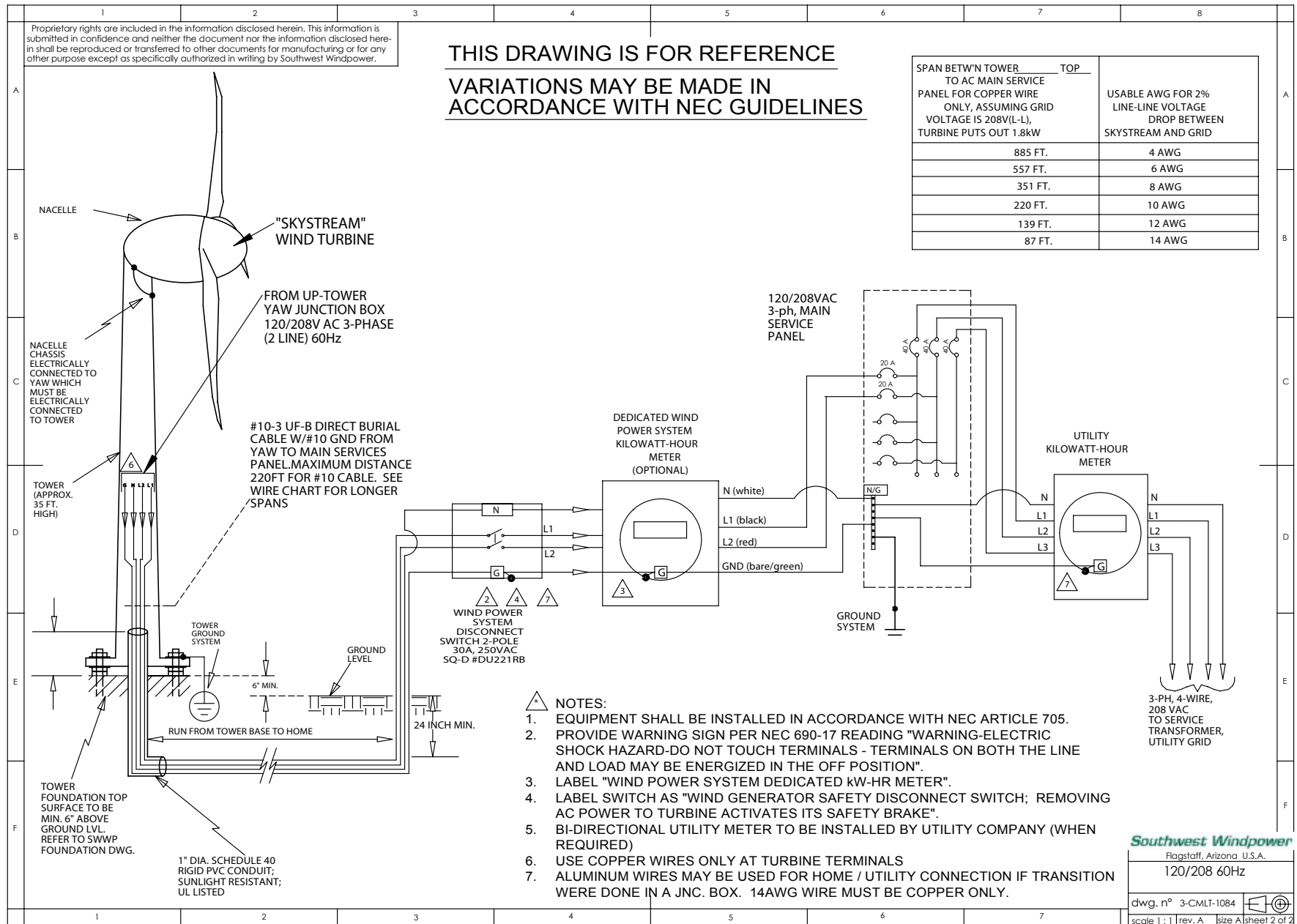

Fig. 5. Grid Connection Option E: 230 V, 1 Phase, Junction Box at Tower Base

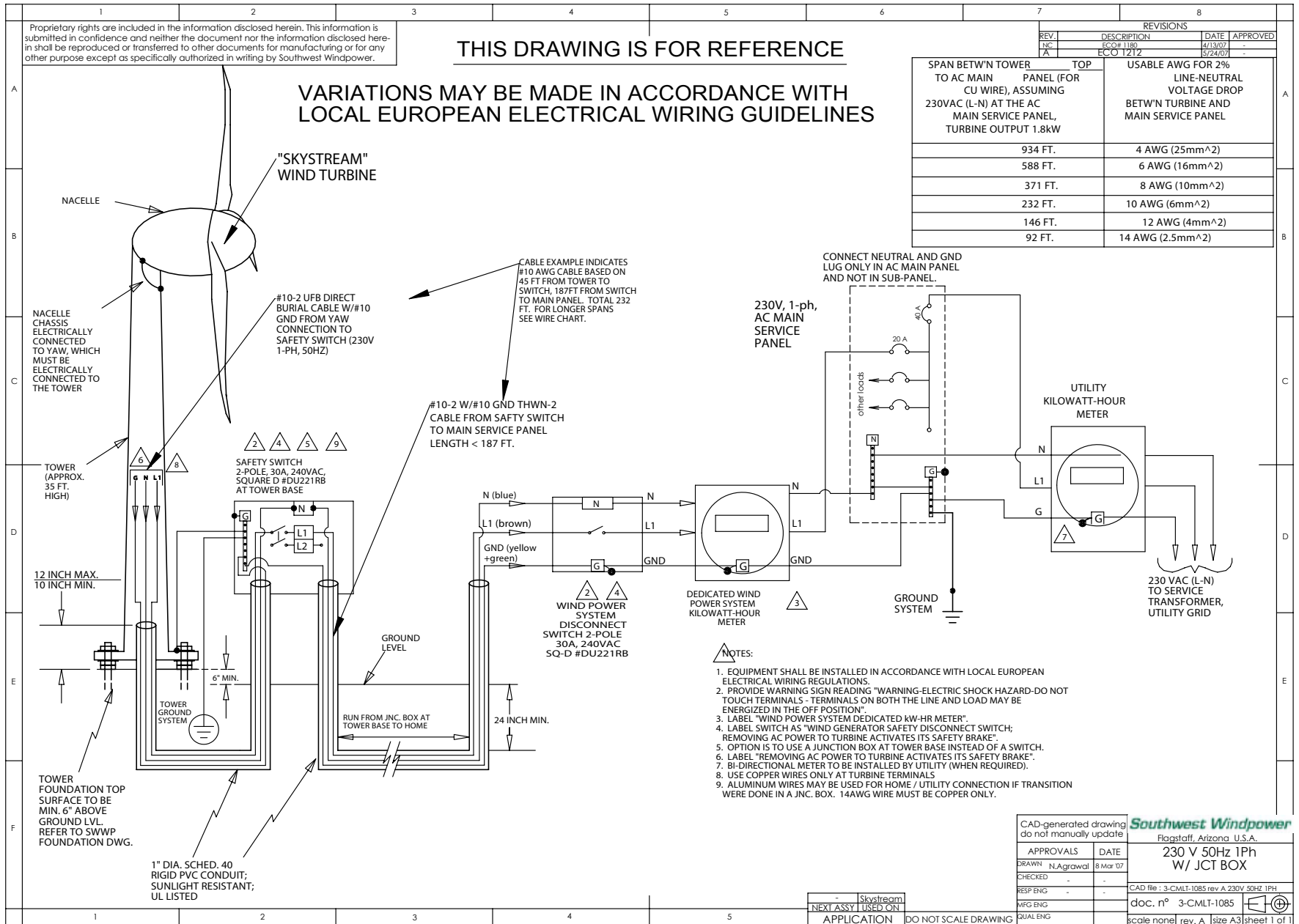



Fig. 6. Battery Backup Option A: 120/240 V Battery Charging System Using Dual Inverters

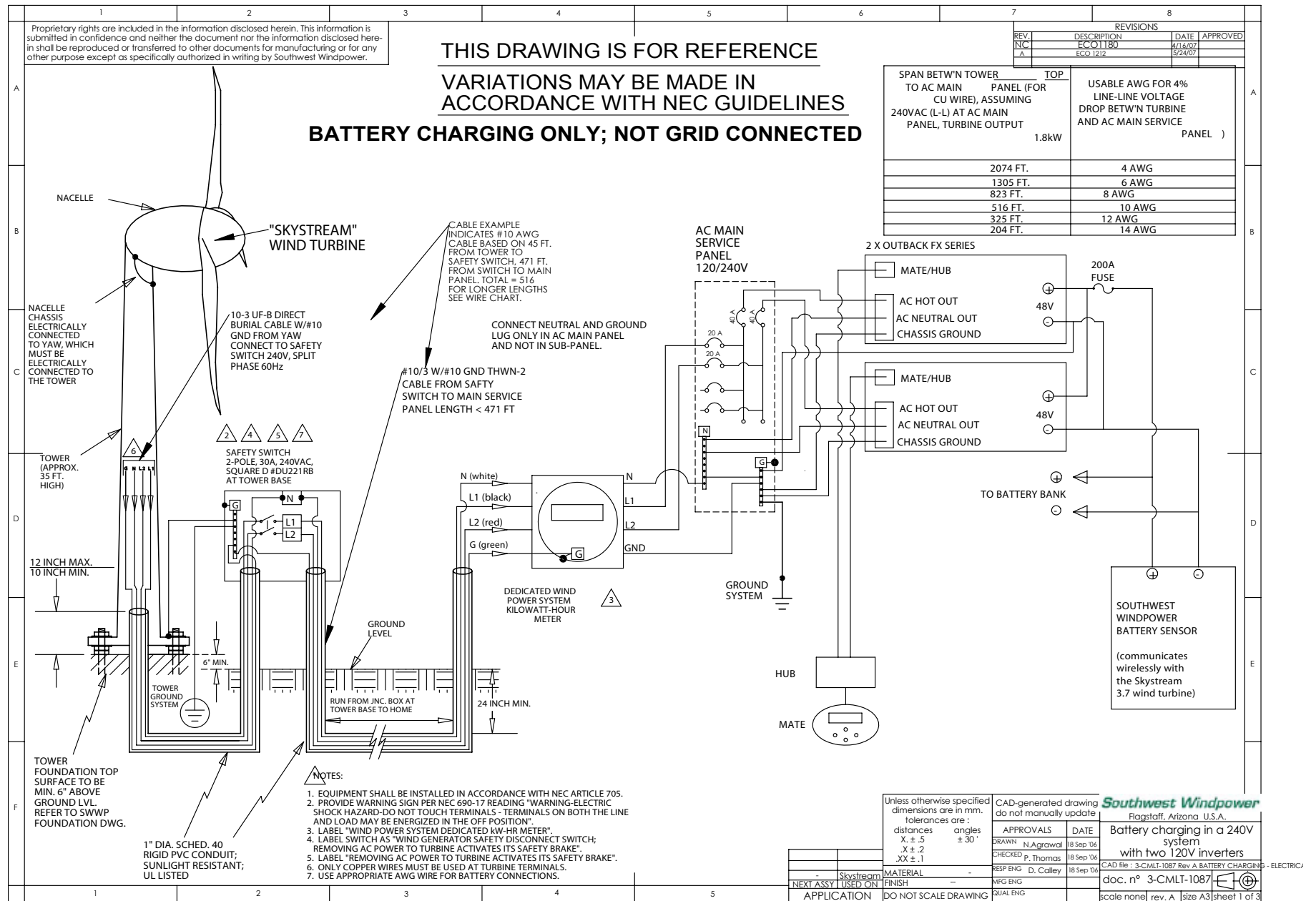

Fig. 7. Battery Backup Option B: 120/240 V Battery Charging System Using Autotransformer and Inverter

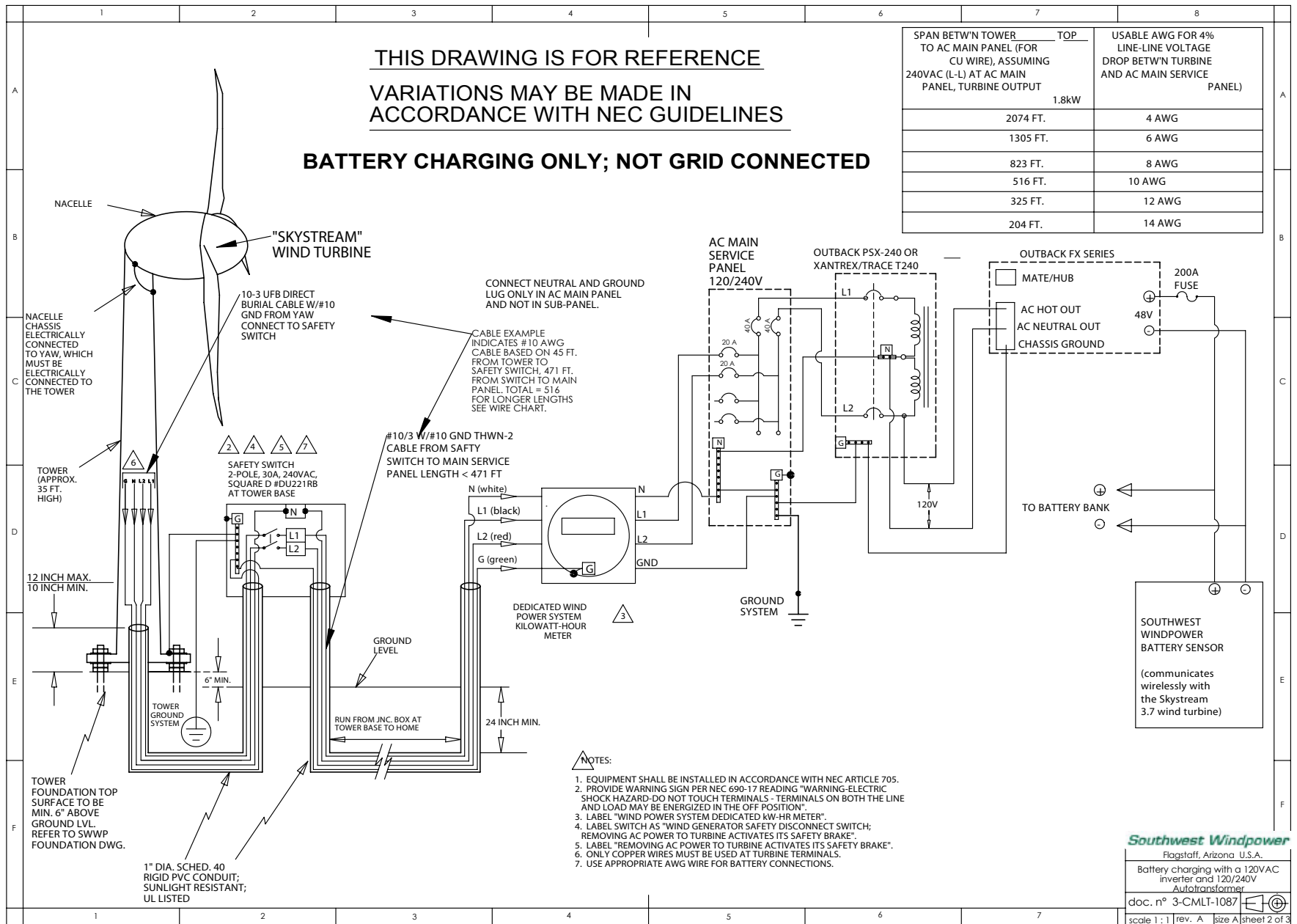

Fig. 8. Battery Backup Option C: 120 V Battery Charging System Using Single Inverter

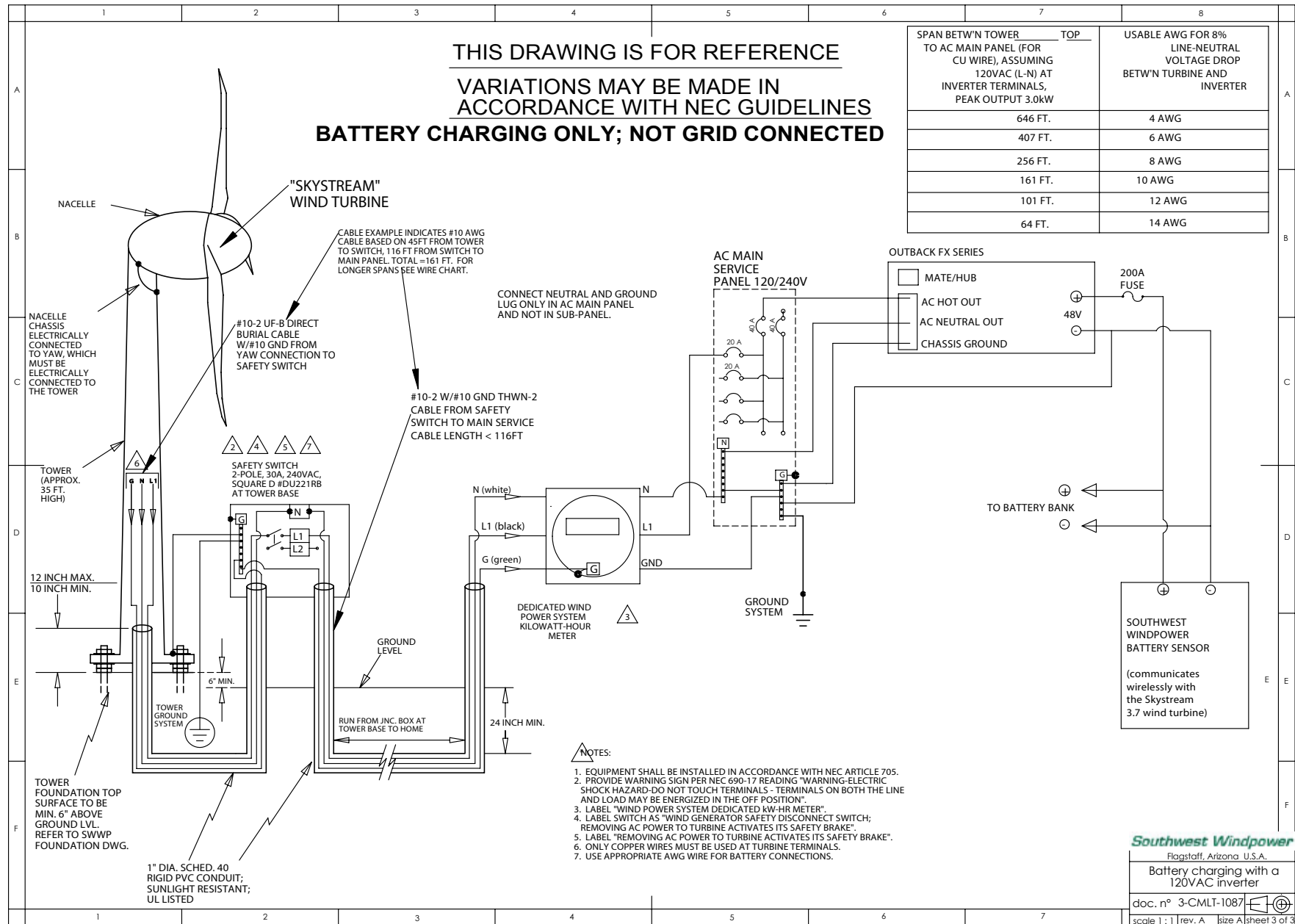

Fig. 9. Battery Backup Option D: 230 V, 1 Phase, Junction Box at Tower

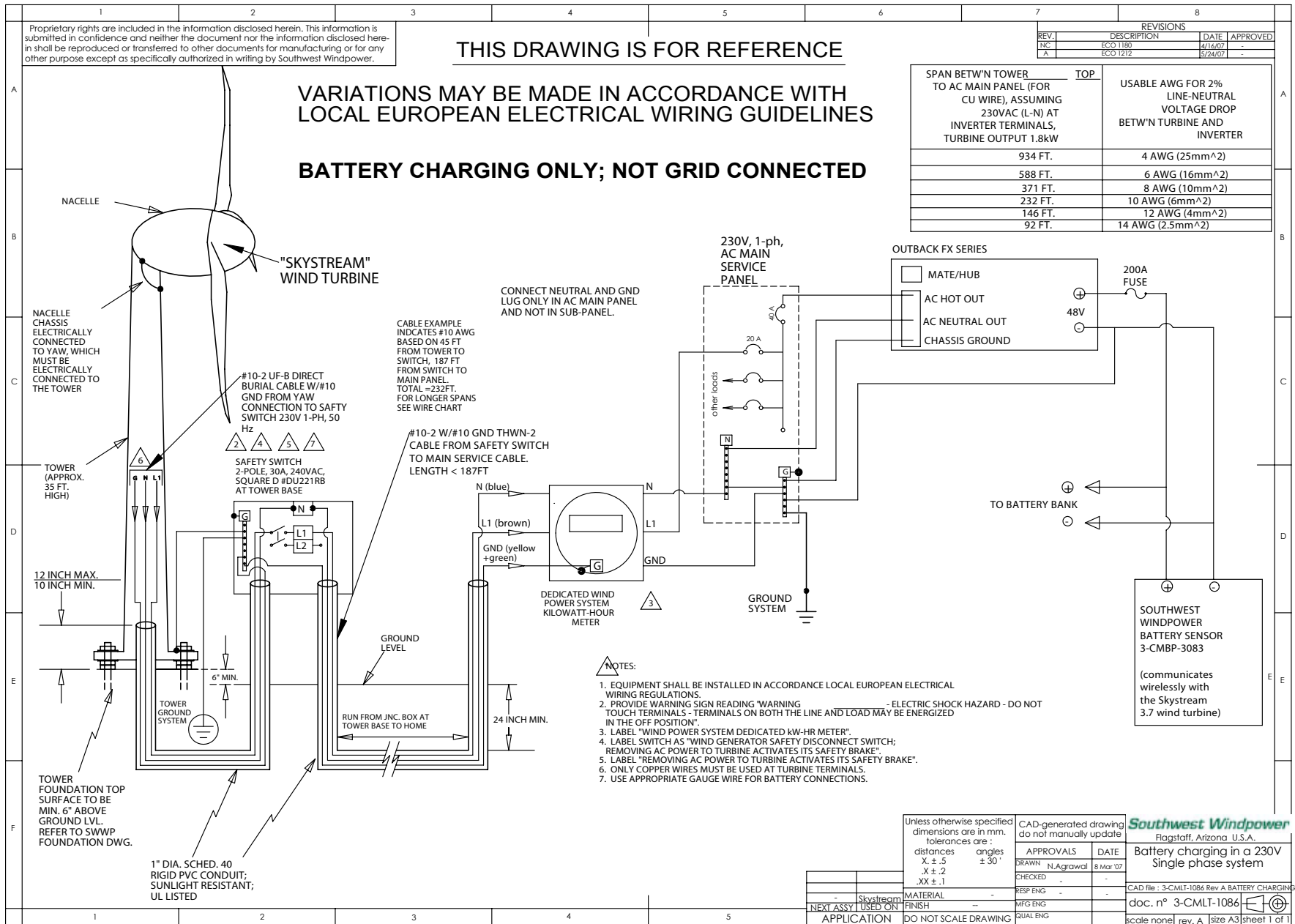

Fig. 10. Battery Charging, Grid Connected, Option A: 120/240 V Battery Charging, Grid Connected Using Dual Inverters

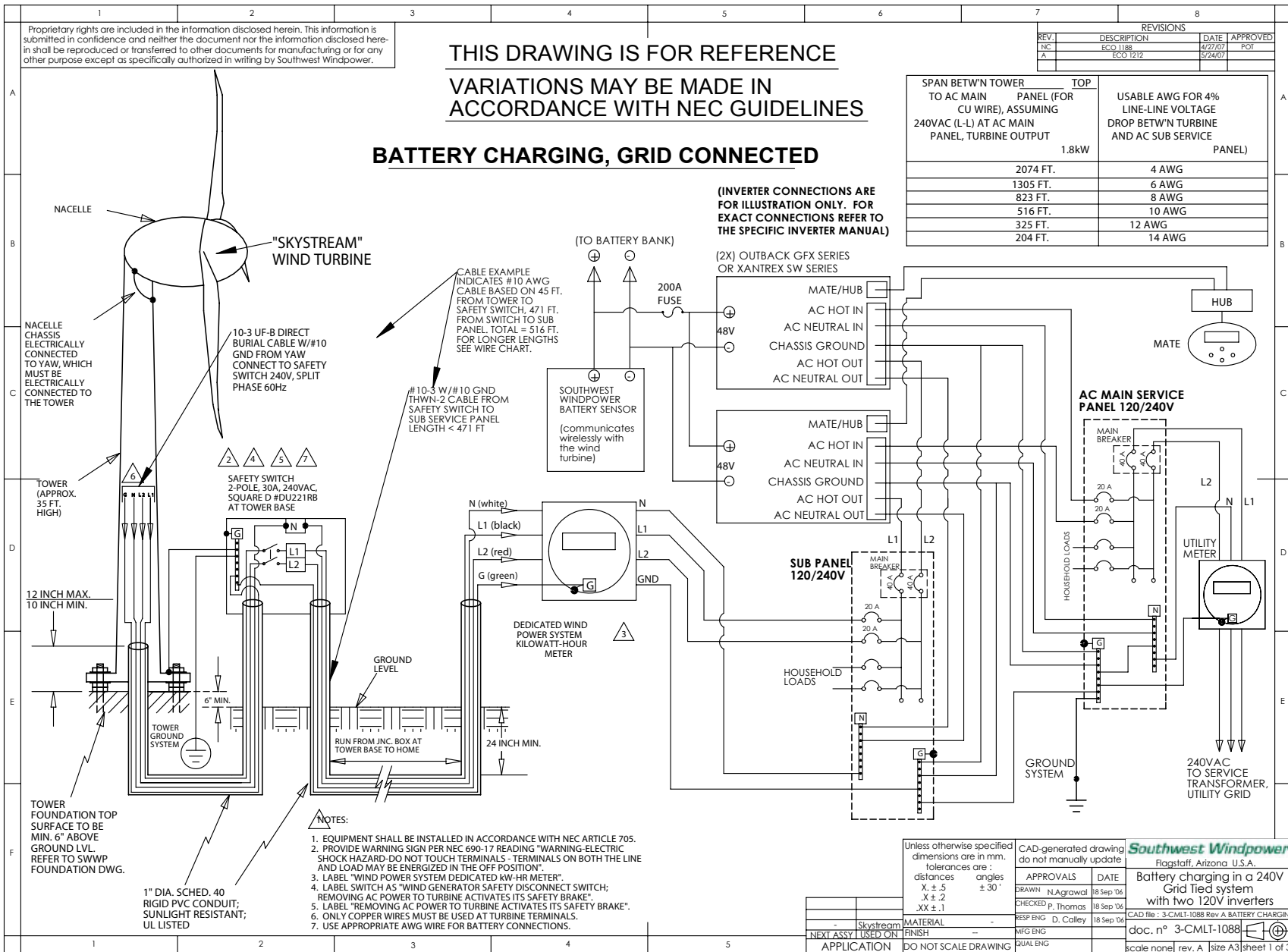

Fig. 11. Battery Charging, Grid Connected, Option B:  
120/240 V Battery Charging, Grid Connected Using Autotransformer and Inverter

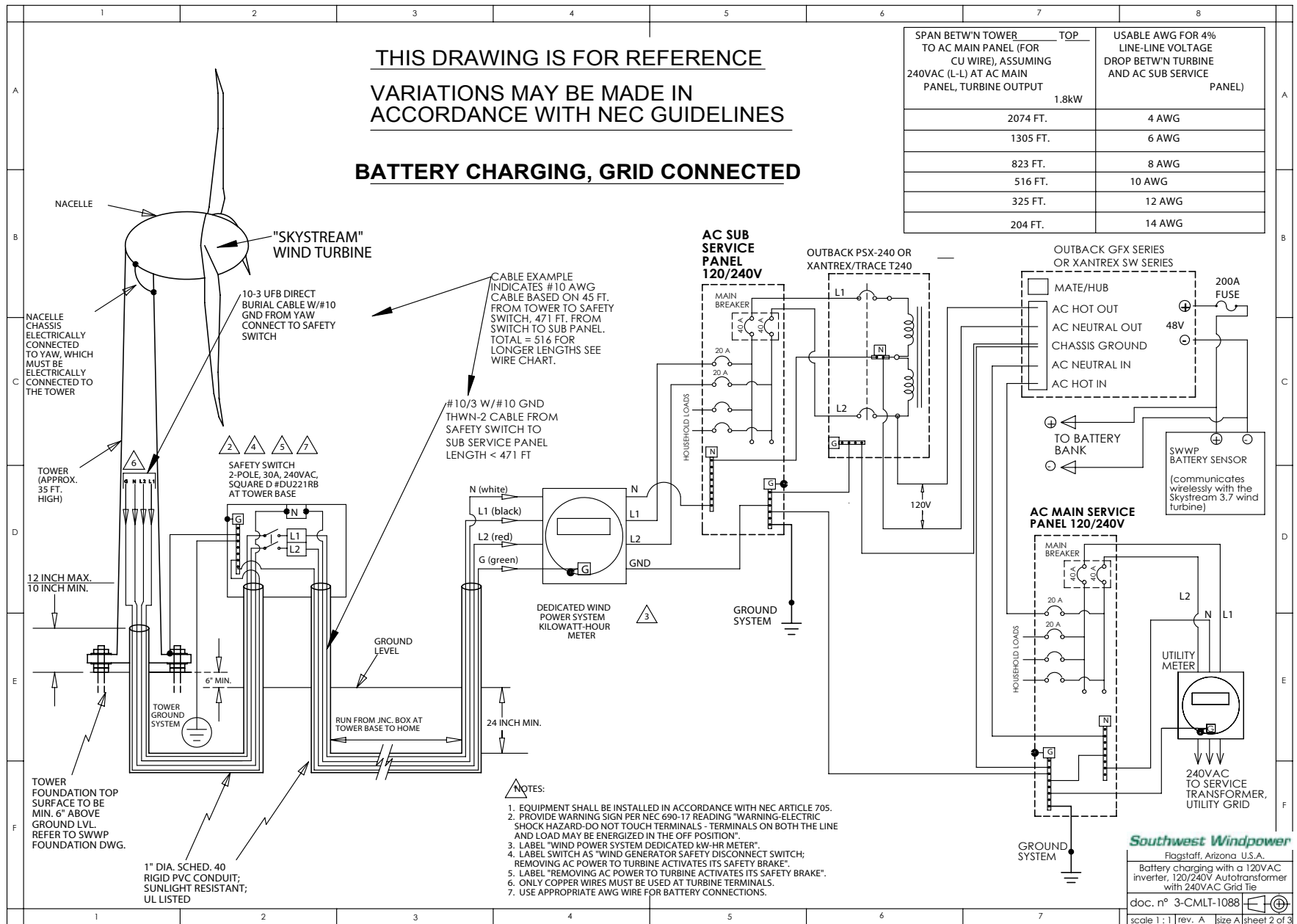
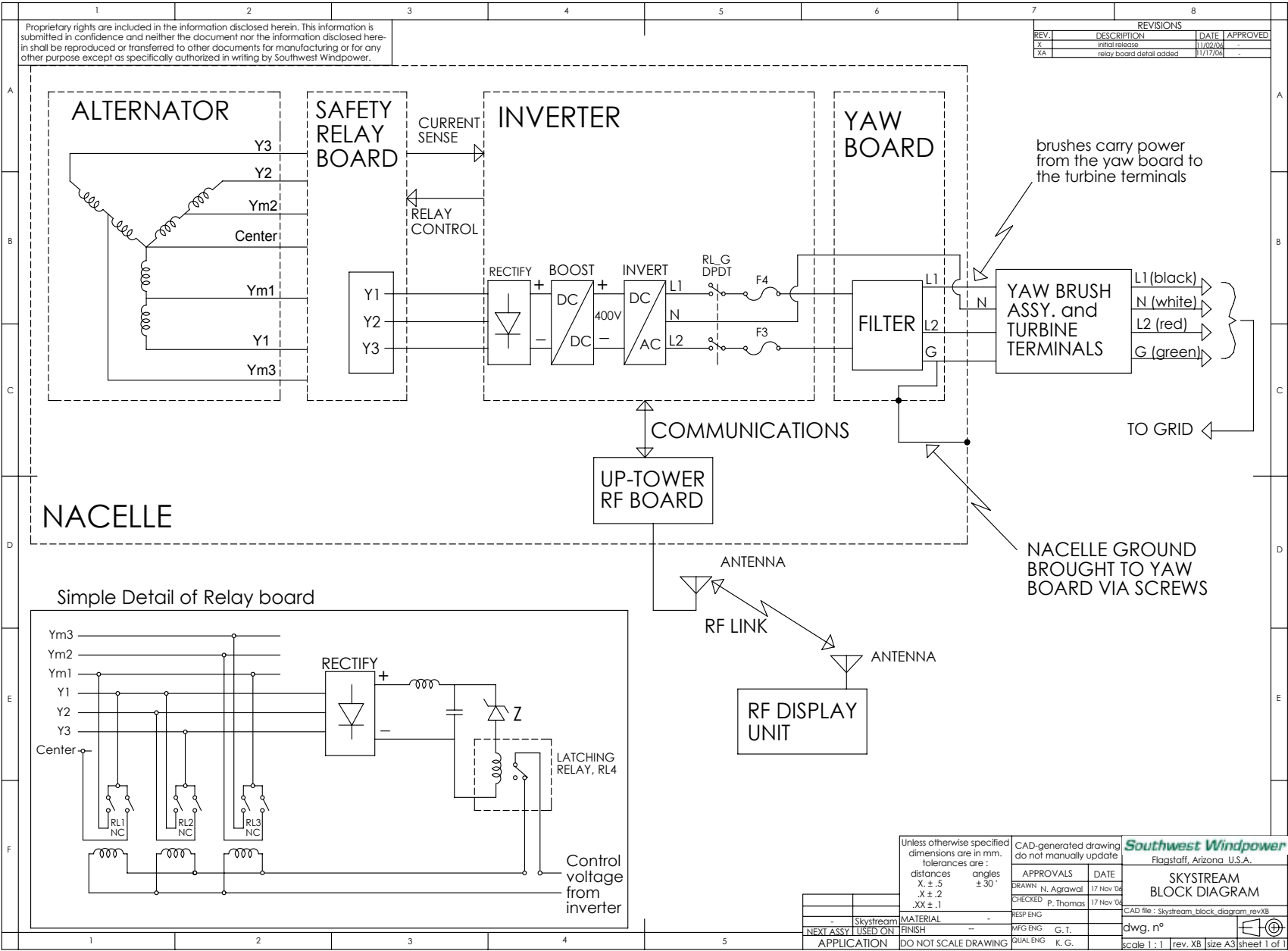



Fig. 13. Skystream Block Diagram





# SKYSTREAM 3.7™

## APPENDIX B TOWER GROUNDING

### Skystream Monopole Towers

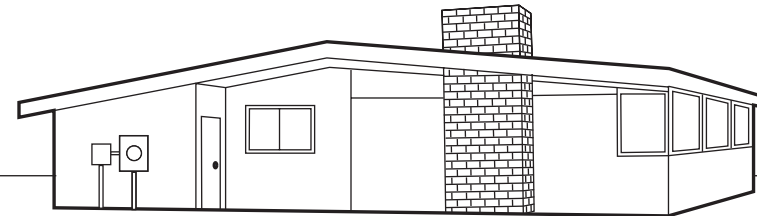
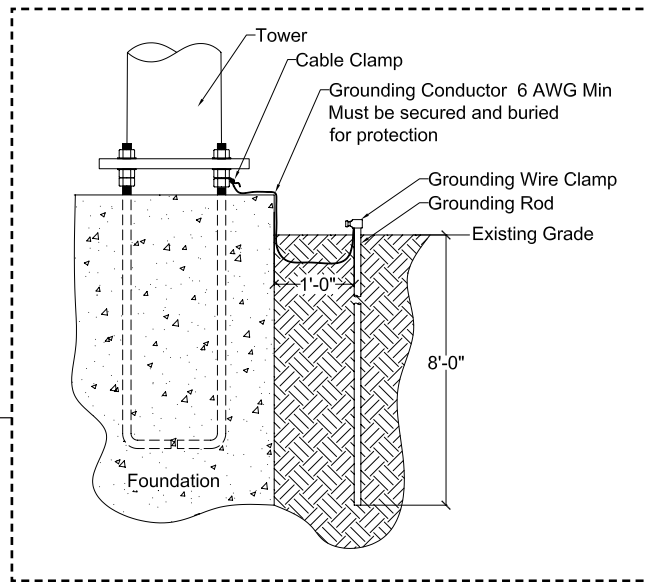
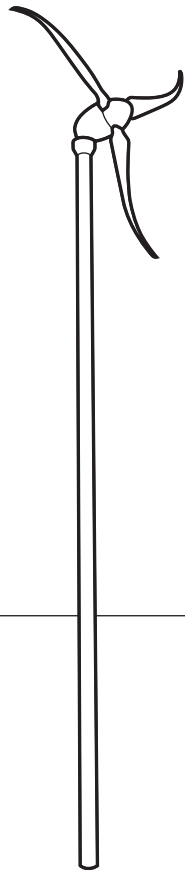

Southwest Windpower, Inc.  
1801 West Route 66  
Flagstaff, Arizona 86001  
Phone: 928.779.9463  
Fax: 928.779.1485

[www.skystreamenergy.com](http://www.skystreamenergy.com)

MADE IN THE USA © July 2007 Southwest Windpower, Inc.  
All Rights Reserved.

# Skystream 3.7 Owner's Manual

## Appendix B: Tower Grounding

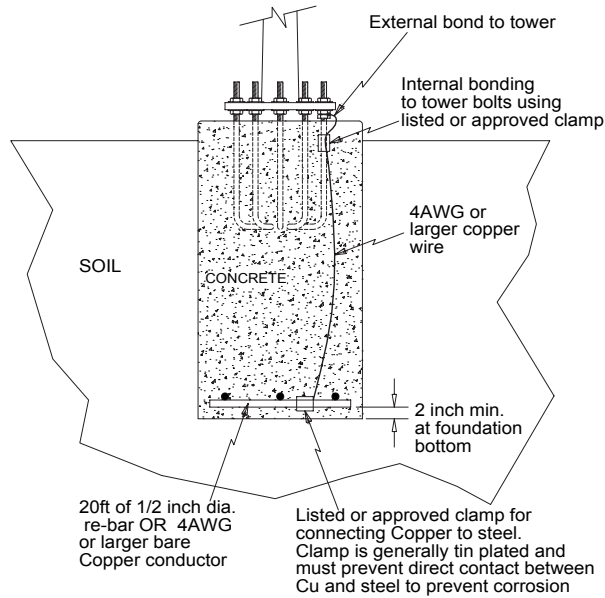

Important Safety Instructions \_\_\_\_\_ 3

**1) INTRODUCTION** \_\_\_\_\_ 4

**2) GROUNDING TECHNIQUES** \_\_\_\_\_ 4

2-1 Copper Clad Electrodes Driven Into Soil \_\_\_\_\_ 4

2-1-1 Grounding Electrode Installation \_\_\_\_\_ 5

2-1-2 Electric Resistance to Ground \_\_\_\_\_ 5

2-1-3 Grounding Electrode Conductor: Material, Size,  
Bonding to Electrode & Bonding to Tower \_\_\_\_\_ 6

2-1-4 Conductor Size \_\_\_\_\_ 6

2-1-5 Bonding the Grounding Electrode Conductor to  
the Earth Electrode \_\_\_\_\_ 6

2-1-6 Bonding the Grounding Electrode Conductor to the  
Tower \_\_\_\_\_ 6

2-1-6-1 Using a Tower Bolt/Nut Assembly \_\_\_\_\_ 6

2-1-6-2 Using a Grounding Lut at Tower Base \_\_\_\_\_ 7

2-1-6-3 Using Exothermic Welding \_\_\_\_\_ 7

2-2 Electrodes Encased in the Concrete of the Tower Foundation

2-3 Bolting Grounding Lug to Tower Base \_\_\_\_\_ 8

## IMPORTANT SAFETY INSTRUCTIONS

READ THESE INSTRUCTIONS IN THEIR ENTIRETY BEFORE INSTALLING.



**Professional installation**  
highly recommended

- 1) **SAVE THESE INSTRUCTIONS.** This manual contains important instructions for grounding your Skystream monopole tower.
- 2) Read these instructions in their entirety before beginning.
- 3) Do not start installation unless all required equipment and tools are on site.

### In this guide



**TIP:** Helpful information to ease the installation



**Professional installation**  
highly recommended



**Warning:** Risk of injury or death - proceed with extreme caution

## One - Introduction

Even though the wind turbine is grounded at the service panel it must also be grounded at the tower base. Grounding the tower at its base may prevent electrical shocks, voltage surges and static charge build up. Proper tower grounding may also limit or minimize damage due to lightning strikes.

This document provides recommendations for grounding small wind turbine systems with rated line currents of less than 200A to achieve compliance with the 2005 USA National Electrical Code (NEC) as well as IEC (International Electrotechnical Commission) standard 60364-5-54 Selection and Erection of Electrical Equipment – Earthing Arrangements, Protective Conductors and Protective Bonding Conductors.

The grounding information contained in this document is provided as a reference. Please refer to the aforementioned NEC and IEC standards for complete detailed information. Local building codes and electrical standards may differ from the information presented here and have precedence over this document.

## Two - Grounding Techniques

There are several tower grounding techniques compliant with NEC and IEC standards, this document presents two of the most common approaches:

- **Copper clad electrodes driven into the soil**
- **Electrodes encased in the concrete of the tower foundation**

### 2-1 Copper Clad Electrodes Driven Into the Soil

The figure 1 depicts a typical tower grounded using an electrode driven into the soil.

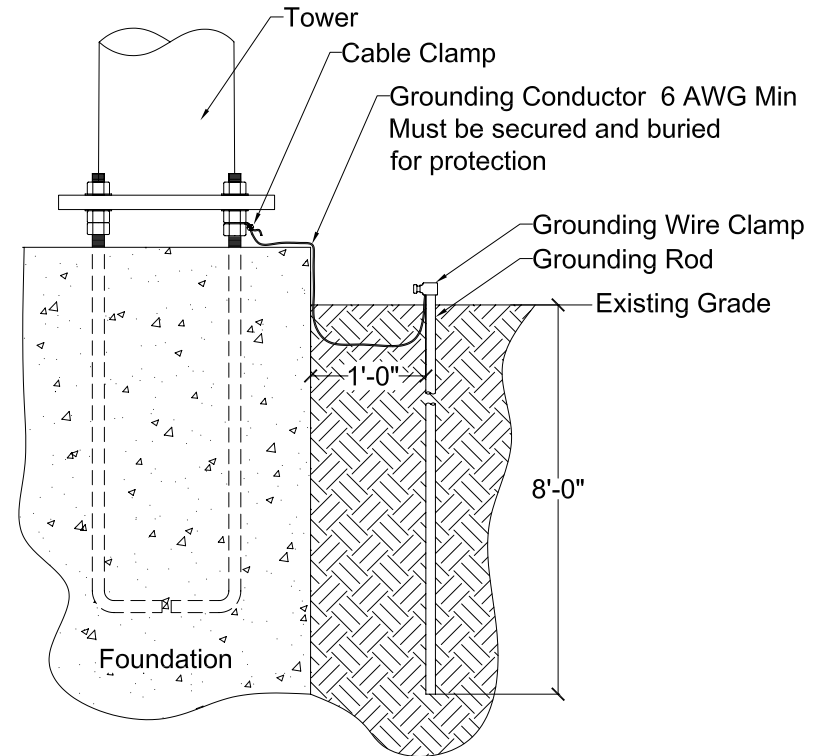

Fig. 1 Electrode driven into ground.

The tower may be grounded using a copper-clad electrode(s) of appropriate diameter and length. See the section entitled “Electrode resistance to ground” to determine the dimensions of the rod. The electrode shall be free from non-conductive coatings such as paint or enamel. Rod and pipe electrodes shall not be less than 8 ft (2.5 m) in length and shall consist of the following materials:

- a) Electrodes of pipe or conduit (hollow electrodes) shall not be smaller than metric designator 21 (trade size 3/4) and, where of iron or steel, shall have the outer surface galvanized or otherwise metal-coated for corrosion protection.

- b) Electrodes of rods of iron or steel shall be at least 15.87 mm (5/8 in) in diameter. Stainless steel rods less than 16 mm (5/8 in) in diameter, nonferrous rods, or their equivalent shall be listed\* and shall not be less than 13 mm (1/2 in) in diameter.

Other grounding electrode types may be used as recommended in 2005 NEC section 250.52 and in accordance with the user's local electrical code authority.

\*Be included in a list published by an organization (or marked as such) that is acceptable to the local authority having jurisdiction in the area. For example, UL/CSA listed in USA/Canada.

### 2-1-1 Grounding Electrode Installation

The following information is excerpted from the 2005 NEC article 250.53 (G). Refer to code for additional detailed information.

The electrode shall be installed such that at least 8 ft (2.44 m) of length is in contact with the soil. It shall be driven into undisturbed soil within 1 ft of the tower foundation. It shall be driven to a depth of not less than 8 ft (2.44 m) except that, where rock bottom is encountered, the electrode shall be driven at an oblique angle not to exceed 45 degrees from the vertical or, where rock bottom is encountered at an angle up to 45 degrees, the electrode shall be permitted to be buried in a trench that is at least 30 in (750 mm) deep. The upper end of the electrode shall be flush with or below ground level unless the aboveground end and grounding electrode conductor are protected against physical damage as specified below (quoted from 2005 NEC article 250.10):

- a) In installations where they are not likely to be damaged.
- b) Where enclosed in metal, wood, or equivalent protective covering.

### 2-1-2 Electrode Resistance to Ground

The resistance to earth of a single ground rod can be calculated using Dwight's equation:

$R = [r/(2\pi L)] \times [\ln(4L/R) - 1]$ , where  $r$  is the soil resistivity,  $L$  is the length of the rod buried inside the earth and  $R$  = radius of the rod;  $\ln$  stands for the natural logarithm.

For calculating the resistance of the rod to ground, one must know the value of soil resistivity. This may be found in the local electrical code or building inspector's office/municipal office or by an actual soil resistivity test.

The resistance of a rod electrode to ground may be lowered by increasing the rod diameter, increasing the buried length of the rod or by treatment of the soil to reduce its resistivity.

If the single chosen electrode does not have a resistance to ground of 10 ohm or less, it shall be augmented by additional electrodes as necessary. The overall resistance of multiple rods to ground would roughly equal the resistance of a single rod to ground divided by the number of rods. Where multiple such electrodes are installed to meet the above requirement, they shall not be less than 6 ft (1.8 m) apart. The multiple rods must be bonded together using the grounding electrode conductor.

### **2-1-3 Grounding Electrode Conductor: Material, Size, Bonding to Electrode and Bonding to Tower**

Material (Ref. 2005 NEC articles 250.62, 250.96(A)).

The grounding electrode conductor shall be of copper, aluminum, or copper-clad aluminum. The material selected shall be resistant to any corrosive condition existing at the installation or shall be suitably protected against corrosion. The conductor shall be solid or stranded, insulated, covered or bare. Any non-conductive paint, enamel, or similar coating shall be removed at threads, contact points, and contact surfaces or be connected by means of fittings designed so as to make such removal unnecessary.

**Note:** Many local electrical standards do not permit the use of aluminum or copper-clad aluminum conductor and strictly require the use of copper conductors.

### **2-1-4 Conductor Size**

(Ref. 2005 NEC article 250.66(A)):

Where the grounding electrode conductor is connected to rod, pipe or plate electrodes, that portion of the conductor that is the sole connection to the grounding electrode shall be a minimum of 6AWG copper wire or 4AWG aluminum wire.

### **2-1-5 Bonding the Grounding Electrode Conductor to the Earth Electrode**

(Ref. 2005 NEC article 250.70):

The grounding or bonding conductor shall be connected to the grounding electrode by exothermic welding, listed lugs, listed pressure connectors, listed clamps, or other listed means. Connections depending on solder shall not be used. Ground clamps shall be listed (approved) for the materials of the grounding electrode and the grounding electrode conductor and, where used on pipe, rod or other buried electrodes, shall also be listed for direct soil burial.

### **2-1-6 Bonding the Grounding Electrode Conductor to the Tower**

The grounding conductor may be connected to the tower by any one the following means:

#### **2-1-6-1 Using a Tower Bolt/Nut Assembly**

- a) Pre-assemble the extra nut (supplied in the tower bolt kit) on one of the tower bolts containing nuts "A" or "B" as shown in fig. 2C of Skystream Foundation and Tower Installation Manual. Move the extra nut towards the bottom of the bolt so that it does not interfere with the nut to go on top of it.
- b) Assemble the nut and washer on top as explained in the Installation Manual. Generously apply a listed "joint compound" to the sandwiching surfaces of the two nuts as well as to the tower bolt in question. The joint compound must be of the type to prevent corrosion between copper and galvanized steel.
- c) Take one end of the grounding conductor and loop it once around the tower bolt containing the extra nut, between the upper and lower nut. Generously apply joint compound to the grounding conductor and cable clamp in the area of attachment. Secure the conductor with a cable clamp around the loop so that it just clears the tower nuts and keeps the loop snug around the tower bolt (see fig. 3). The cable clamp is required so that the ground wire does not slip out from between the nuts when the lower nut is tightened.
- d) Ensure that surfaces of the lower and upper nuts facing each other are free of dirt and have very clean surfaces. If necessary, wash and clean these surfaces. This is essential for a good electrical connection between the ground conductor and the tower. Tighten the lower nut towards the upper nut applying sufficient torque (50 lb-ft or 68 N-m minimum) to securely clamp the grounding wire (see fig. 3).
- e) Erect the tower and level it as required by adjusted any or all of the tower nuts. You may have to loosen the ground wire nut during this adjustment. After finished adjusting the tower level, re-tighten the lower nut to the suggested torque to make sure the ground wire is securely sandwiched and bound between the two nuts.

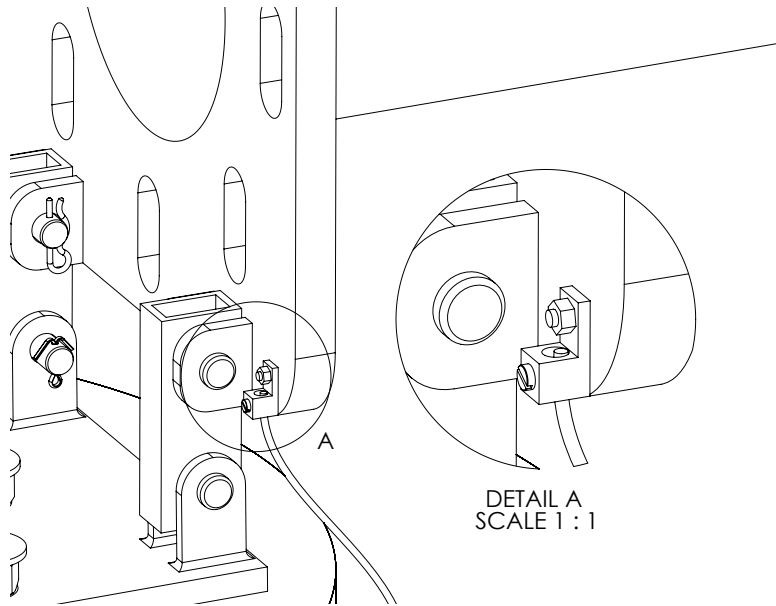

Fig. 2 Attaching the grounding wire to the tower base.

### 2-1-6-2 Using a Grounding Lug at Tower Base

Bond the grounding conductor to the tower base flange through a ground terminal lug attached to the tower base as shown in figure 2. Use a 1/4-20 x 1.75 in long stainless steel bolt through a hole in the tower base and a Nyloc stainless steel nut to fasten the ground lug to the underside of the tower base. The ground lug must be UL listed and must be type to that accommodates up to 1/0 AWG wire minimum.

### 2-1-6-3 Using Exothermic Welding

Bond the grounding conductor to the tower base flange by exothermic welding of the conductor to the base flange. Make exothermic welds strictly in accordance with the weld manufacturer's written recommendations.

Electrode conductor routing and placement / installation:

Ensure that the grounding conductor has no sharp bends in it. This is important to keep its inductance low. The grounding conductor may be buried or contained in a conduit as explained in 2005 NEC article 250.64.

### 2-2 Electrodes encased in the concrete of the tower foundation (reference 2005 NEC article 250.52(A)(3))

A grounding electrode may also be encased in the concrete of the tower foundation. The electrode is located at the bottom of the foundation and connects to the tower mounting "J" bolts and to the tower base by means of a grounding conductor.

Because the grounding electrode will be encased in concrete it should be inspected and approved prior to pouring the foundation to avoid conflicts with local construction inspectors.

Two types of electrodes, their locations and their connection to the electrode grounding conductor are described below:

- a) The Electrode must be at least 20 ft (6.0 m) of one or more (electrically connected by steel tie wires) bare or zinc galvanized steel or other electrically conductive coated steel reinforcing bars or rods of not less than 1/2 in (13 mm) in diameter, located near the bottom of the concrete foundation that is in direct contact with the earth. The electrode must be encased by at least 2 in (50 mm) of concrete as shown in figure 4. The reinforcing bars, if bare, must not be rusted at the time of installation to prevent bad electrical connection between bars and with the grounding electrode conductor. The reinforcing bars must be electrically connected to the anchor bolts either using the steel tie wires or using the grounding electrode conductor. The grounding electrode conductor must not be smaller than 4AWG copper and must be electrically bonded to the bottom reinforcing bars using listed/approved means that is suitable for concrete encasement. Sufficient extra length of the conductor must be available to bring it out of the foundation top and at least 18 in above the foundation top. It should then be bonded to the tower as described in section 1.5 of this document.
- b) The Electrode must be least 20 ft (6.0 m) of bare copper conductor not smaller than 4AWG. The copper conductor, which may be in the

form of a coil, must lie at the bottom of the foundation with either a 2-in thick (maximum) tamped fill of earth covering the grounding coil or covered in concrete a maximum of 2 in above the soil at the bottom of the foundation. Sufficient extra length must be present in the copper conductor to bring it at least 18 inch above the foundation top where it should be bonded to the tower as described in section 1.5 of this document. On its way up, the copper conductor must also be bonded to the tower anchor bolts using a clamp listed or approved means that is suitable for concrete encasement and also suitable for connecting copper to steel. This listed clamp is generally tin plated and must be of the type to prevent direct contact between copper and steel to prevent corrosion.

### 2-3 Bolting Grounding Lug to Tower Base

An alternate method of attaching the electrode grounding conductor to the tower is to drill a hole through the base and utilize a commercially available lug as depicted in figure 2. To connect the grounding conductor to the tower base using this approach drill a 0.25 in (6 mm) hole through the tower base. After joining the grounding conductor to the listed lug according to the lug manufacturer's instructions, bolt the lug to the tower base with a stainless steel bolt and self locking nut. The listed lug is generally tin plated and prevents corrosion between the galvanized steel tower and the copper conductor.

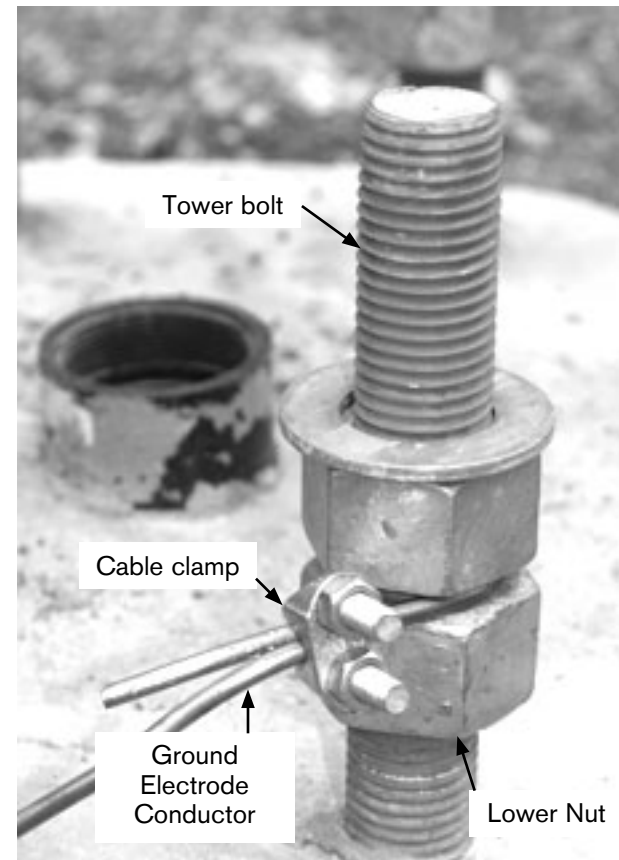

Fig. 3 Tower foundation bolt.



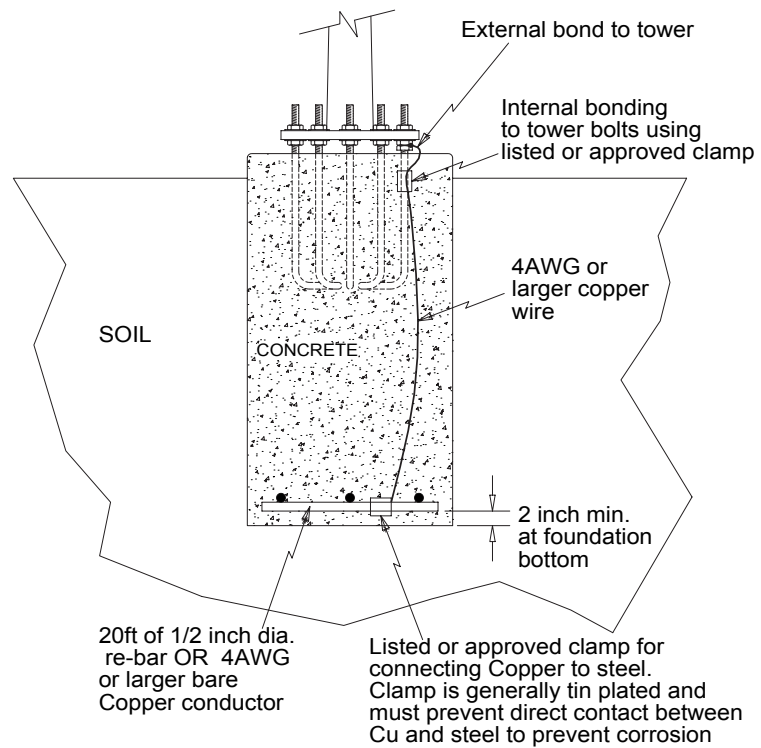
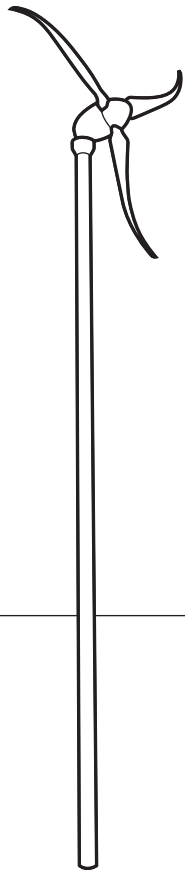

Fig. 4 Concrete encased electrode.



# SKYSTREAM 3.7™

## APPENDIX C CERTIFICATION/ COMPLIANCE



Skystream 3.7, Land, 230V, 50Hz, 1Ph (Item# 1-S)  
Skystream 3.7, Marine, 230V, 50Hz, 1Ph (Item# 1-M)

Declare that Skystream 3.7 small wind turbine meets the essential requirements by design and construction as follows:

Comply with the Machinery Directive 98/37/EC.  
Comply with the small wind turbine design standard IEC 61400-2

Comply with Directive 2005/88/EC for noise limits and labeling.  
We comply to all safety aspects of the Low Voltage Directive and is certified in USA to comprehensive safety standards UL1741

Comply to the R&TTE directive 99/5/EC and will have undergone testing by Underwriters Laboratories to document conformity to the standard.

Will comply to the EMC directive 2004/108/EC by August 1, 2006 and will be 100% compliant to RoHS directive 2002/95/EC and will fully comply to the standard.

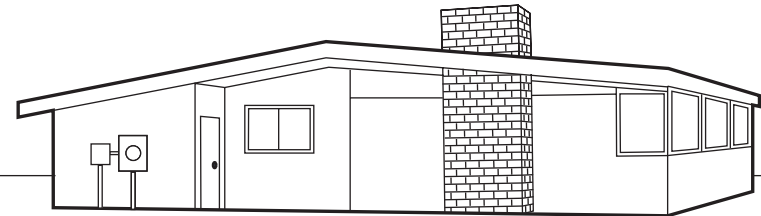

Southwest Windpower, Inc.  
1801 West Route 66  
Flagstaff, Arizona 86001  
Phone: 928.779.9463  
Fax: 928.779.1485

[www.skystreamenergy.com](http://www.skystreamenergy.com)

MADE IN THE **USA**

© April 2007 Southwest Windpower, Inc.  
All Rights Reserved.

# Certificate of Compliance

Certificate Number 20071402E300731  
Report Reference E300731, Issued 2006-10-17  
Issue Date 2007 February 14

Page 1 of 1



## Southwest Windpower Inc

1801 W Rte 66  
Flagstaff, AZ 86001  
United States

*This is to certify that representative samples of*

### Skystream Inverter

Component inverter for use with Skystream wind turbine, Utility Interactive Ready



*Have been investigated by Underwriters Laboratories Inc.® in accordance with the Standard(s) indicated on this Certificate.*

**Standard(s) for Safety:**

UL 1741, Standard for Safety for Inverters, Converters, Controllers and Interconnection System Equipment for Use With Distributed Energy Resources, 1st Ed.; IEEE 1547-2003; CAN/CSA-C22.2 No.107.1-01, 3rd Ed., General Use Power Supplies

**Additional Information:**

Output configuration: 120/240V, L-N-L, Oper. voltage range Vac: 212-264; or 120/208V, L-N-L, Oper. voltage range Vac: 183-229; Normal out frequency Hz: 60.0; Operating frequency range Hz: 59.3-60.5; Rated output current Aac: 10.0; Rated continuous output power kW@25 °C: 1.8; Rated continuous output power kW@50°C: 1.4; Max. peak output kW: 2.4; Surge Rating B3

Only those products bearing the UL Recognized Component Marks for the U.S. and Canada should be considered as being covered by UL's Recognition and Follow-Up Service and meeting the appropriate U.S. and Canadian requirements. The UL Recognized Component Mark for the U.S. generally consists of the manufacturer's identification and catalog number, model number or other product designation as specified under "Marking" for the particular Recognition as published in the appropriate UL Directory. As a supplementary means of identifying products that have been produced under UL's Component Recognition Program, UL's Recognized Component Mark  may be used in conjunction with the required Recognized Marks. The Recognized Component Mark is required when specified in the UL Directory preceding the recognitions or under "Markings" for the individual recognitions. The UL Recognized Component Mark for Canada consists of the UL Recognized Mark for Canada:  and the manufacturer's identification and catalog number, model number or other product designation as specified under "Marking" for the particular Recognition as published in the appropriate UL Directory.

## Look for the UL Recognized Component Mark on the product

Issued by: Chris Storbeck  
Chris Storbeck, Project Engineer

Reviewed by: ChristopheFlueckiger  
Christophe Flueckiger, Sr. Project Engineer

Underwriters Laboratories Inc.  
Any information and documentation involving UL Mark services are provided on behalf of Underwriters Laboratories Inc. (UL) or any authorized licensee of UL.  
For questions in The United States of America you may call 1-877-UL-HELP.

# Declaration of Conformity



For battery charging applications only

---

**Product:** **Skystream 3.7**

**Type:** Skystream 3.7, Land, 230V, 50Hz, 1Ph (Item# 1-SSL-11-230)  
Skystream 3.7, Marine, 230V, 50Hz, 1Ph (Item# 1-SSM-11-230)

We hereby declare that Skystream 3.7 small wind turbine meets the essential European Union requirements by design and construction as follows:

- We fully comply with the Machinery Directive 98/37/EC.
- We fully comply with the small wind turbine design standard IEC 61400-2.
- We fully comply with Directive 2005/88/EC for noise limits and labeling requirements.
- We believe we comply to all safety aspects of the Low Voltage Directive 2006/95/EC as this product is certified in USA to comprehensive safety standards UL1741 / IEEE 1547.
- We fully comply to the R&TTE directive 99/5/EC and will have undergone the necessary testing by Underwriters Laboratories to document conformity by July 1, 2007.
- We will fully comply to the EMC directive 2004/108/EC by August 1, 2007.
- We are 99% compliant to RoHS directive 2002/95/EC and will fully comply by July 1, 2007.

Based on the above indicated conformance, we are applying the CE-mark to the above models for export to Europe.

**Remark:**

The above CE compliance will be invalidated if:

- The machine is modified in any way without the explicit written consent of Southwest Windpower.
- The machine is used or connected in a manner or configuration that Southwest Windpower does not regard as its intended application.

Dated, April 5, 2007

**David Calley**  
(President and Chief Technology Officer, Southwest Windpower)

**Southwest Windpower**  
1801 West Rt. 66, Suite 100  
Flagstaff, AZ 86001, USA  
Phone: +1 928-779-9463  
[www.windenergy.com](http://www.windenergy.com)  
[info@windenergy.com](mailto:info@windenergy.com)





# SKYSTREAM 3.7™

Southwest Windpower, Inc.  
1801 West Route 66  
Flagstaff, Arizona 86001  
Phone: 928.779.9463  
Fax: 928.779.1485  
[www.skystreamenergy.com](http://www.skystreamenergy.com)